

**SUBJECT: Upfit Body Mounting Guidelines**  
**MODEL YEARS: 2024 & Beyond**  
**AFFECTED MODELS: UU Model THREE**  
**INITIATION DATE: 08/29/2023**  
**REVISION: 10/05/2023**

**AWARENESS:**

**Description of Concerns:**

- Improper Upfit Body mounting practices may not distribute load over the entire chassis while liberal use of Shear Strap and U-Bolt placement could result in a mechanical attachment issue that may impact safe best practices.
- Upfit equipment to close to HIGH VOLTAGE Battery Assemblies.
- Inadequate clearance from the back-of-cab to the upfit body could impede access to under cab servicing and access to chassis components.

**Solution:**

- **Regarding Upfit Body Mounting.**

Proper Upfit Body mounting secures and distributes load over the entire chassis for rigid attachment of Upfit Body to chassis. Continuous mechanical contact to the frame rails fore and aft of the rear axle is necessary for proper load transfer and distribution. Full perimeter use of the load bearing top-of-frame surface contact with hardwood spacers (or equivalent) is strongly recommended. Generous use and placement of U-Bolts and Shear Plates utilizing existing frame rail holes insure proper mechanical attachment. Use proper premium grade fasteners for rigid mechanical attachment of Upfit Body to chassis mounting areas. Welding is permitted in low stress areas of the frame (aft of rear spring shackles).

Acceptable types of attachments.

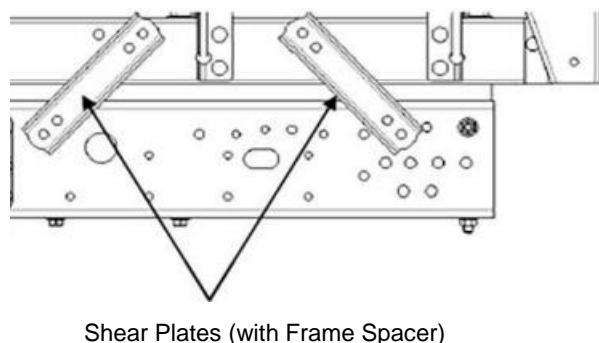
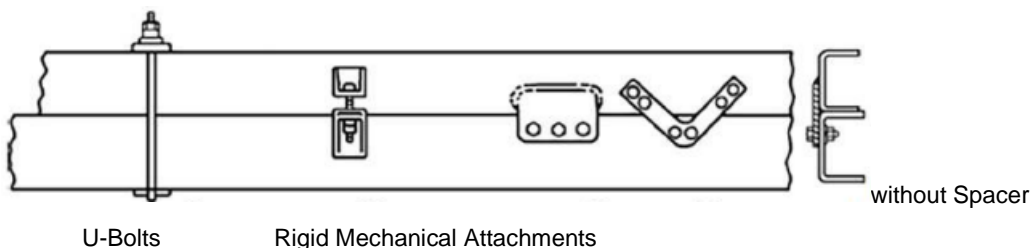

• **Regarding HIGH VOLTAGE Batteries/Components & Wiring.**

- 1) Maintain a minimum static clearance of 150mm / 3” between frame rail mounted HIGH VOLTAGE Batteries/Components/Wiring and Upfit Body/Equipment.
- 2) Do not alter or relocate HIGH VOLTAGE components from the OEM chassis location.
- 3) Do not mount Upfit Body/Equipment to the HIGH VOLTAGE Batteries/Components/Wiring.

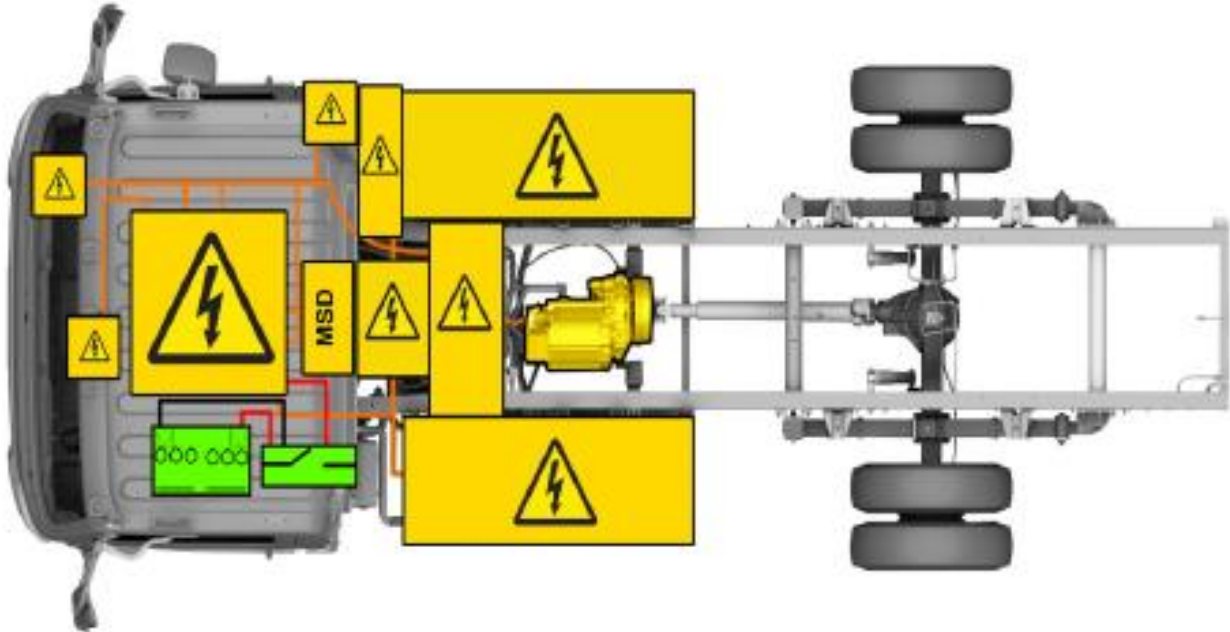

• **Regarding Cab to Upfit Body Gap**

- 1) Maintain a minimum fore/aft clearance of 228mm / 9” from to back-of-cab to upfit body/equipment for service and access to chassis components.
- 2) Do not mount any equipment in the Cab to Upfit Body Gap



Cab to Upfit Body Gap

**Supplemental Content:** [2024 Mullen Upfit Guide \(mullenusa.com\)](https://mullenusa.com)

\*Reference; Mullen U.I. Bulletin #101