

Mullen THREE

Owner's Manual



Based on current specifications and subject to change.

Note: All figures are reference only and Mullen reserves the right to modify any and all information shown, without notification. Options subject to change.

TABLE OF CONTENTS

INTRODUCTION	1
GRAPHICAL TABLE OF CONTENTS	2
GETTING TO KNOW YOUR VEHICLE	3
INSTRUMENTS AND CONTROLS	4
SAFETY	5
STARTING AND OPERATING	6
IN CASE OF EMERGENCY	7
MAINTENANCE AND SERVICE	8
SPECIFICATIONS	9
CUSTOMER ASSISTANCE	10
INDEX	11

OWNER'S MANUAL INTRODUCTION	2
Additional Information	2
STATEMENT	3
DECLARATION	3
HOW TO USE THIS MANUAL	4
Symbols	4
ROLLOVER WARNING	5
VEHICLE MODIFICATIONS / ALTERATIONS	5
Installing of Radio Transmitting Equipment	5
GENERAL DISCLAIMER	6

1
2
3
4
5
6
7
8
9
10
11

INTRODUCTION

OWNER'S MANUAL INTRODUCTION

Thank you for purchasing a Mullen THREE vehicle. It is our hope to bring you a new driving experience with our products and service.

To avoid operation errors, please review this manual to learn about its performance and limitations. Besides operating descriptions, this manual also includes maintenance and driving guidelines. Additionally, this manual goes over environmentally conscious driving habits as well. You should operate, and maintain the vehicles as instructed in this manual.

Due to our company's constant pursuit and innovation on product quality, the company reserves the right to modify products after printing the manual without prior notification and assumes no responsibility.

Thank you again for your decision in choosing Mullen.

CAUTION!

- These instructions are applicable to Mullen THREE vehicles. Certain devices, facilities or functions covered in the owner's manual may not be installed on your vehicles due to different vehicle configurations. Optional systems and devices are marked "if equipped" in the owner's manual.
- Use only a professional upfitting service to modify the vehicle. Only upfit the vehicle with a recommended upfitting service center. Upfit may influence the performance, safety and durability of the full vehicle, and even violate national laws and regulations if not performed properly.
- Please use genuine Mullen parts when replacing components and parts in order to ensure maintenance quality as well as avoid potential safety hazards or vehicle damages resulted from using unapproved accessories.

CAUTION! (Continued)

- In order to maintain optimal vehicle performance, please perform new vehicle break-in maintenance and periodic maintenance according to recommended maintenance intervals in this manual.
- The orange cables are high voltage cables, do not touch where orange cables connect.
- The vehicle is not equipped with "Park" on the gear selector. You must ALWAYS put your vehicle in Neutral and engage the parking brake every time you park. The parking brake lever is located to the right of the driver's seat.
- The company assumes no responsibility for safety accidents caused by violation of aforementioned items or any other direct and indirect losses.
- Mullen products will be constantly updated and improved due to continuous technical improvement and development. The company reserves the right to modify vehicle design, devices and technical characteristics at any time. Therefore, certain information of the owner's manual might be different as the product evolves.

NOTE:

For service, maintenance, or inquiries, refer to the [Customer Assistance p. 162](#) chapter for contact information.

Additional Information

Before driving your vehicle, read your Owner's Manual carefully. This will ensure familiarity with controls and maintenance requirements, assisting you in the safe operation of your vehicle.

⚠ WARNING!**IMPORTANT SAFETY INFORMATION REMINDERS!**

Follow these important driving rules to help ensure a safe and comfortable trip for you and your passengers!

- NEVER drive under the influence of alcohol or drugs.
- ALWAYS observe posted speed limits and never drive too fast for conditions.
- ALWAYS give your full attention to driving and avoid using vehicle features or taking other actions that could distract you, such as using the touchscreen to adjust settings while the vehicle is in motion.
- ALWAYS provide information about the proper use of vehicle safety features to all occupants of the vehicle.
- ALWAYS review this Owner's Manual for important safety information.

STATEMENT

In order to ensure the safety of yourself and your passengers, please read this manual and included instructions carefully. Operate your vehicle strictly in accordance with this manual to prevent accidents.

Make sure to adhere to any laws and regulations.

This manual is distributed by Mullen. No organization or individual has rights over it besides Mullen. This manual is included with the purchase of the vehicle. This vehicle is only to be used for purposes specified in this manual. Mullen, shall not bear any legal responsibility arising from any actions specifically restricted in this manual. The figures/images on the cover and inside this manual are only for reference. If there are any issues between the actual objects equipped in the vehicle and the figures, please refer to the actual objects.

Due to constant technical innovations, Mullen reserves the right to modify and amend this manual.

The rights to this manual are owned by Mullen. Groups or individuals shall not reprint or copy any parts of this manual without authorization.

©2023 Mullen. All Rights Reserved.

DECLARATION**⚠ CAUTION!**

Cautions on accessories, parts, and technical modification

- Your vehicle is provided with active and passive safety features.
- If you need to have aftermarket accessories installed on your vehicle, please consult a Mullen authorized service provider first. A Mullen authorized service provider can give advice and knowledge on what parts and accessories will work with your vehicle.
- It is not recommended to use any parts or accessories on your vehicle not approved by Mullen.
- It is recommended to contact a Mullen authorized service provider before installing any aftermarket devices to ensure it conforms to standards and will not void any warranties.

⚠ WARNING!

Improper repair, maintenance, or technical modifications, may lead to a functional failure, resulting in an accident.

1

2

3

4

5

6

7

8

9

10

11

INTRODUCTION

NOTE:

For service, maintenance, or inquiries, refer to the [Customer Assistance p. 162](#) chapter for contact information.

Technical changes

Any technical modifications must comply with the standards and specifications of Mullen. Any devices or software not approved by Mullen can void the warranty of your vehicle.

Operating your vehicle outside of its limits, such as overloading can also void the warranty.

HOW TO USE THIS MANUAL

Each time a direction instruction (left, right, forward or rearward) is provided regarding the vehicle, it is to be interpreted from the perspective of the driver's seat. In special instances where this rule does not apply, appropriate instructions will be indicated within the text.

The detailed index at the end of this Owner's Manual contains a complete listing of all subjects.

Symbols

The symbols below may be used on your vehicle or throughout this Owner's Manual:

WARNING!

This is used to indicate the presence of a hazard that could cause death or serious personal injury. To avoid or reduce the risk, the procedures must be followed precisely.

CAUTION!

This is used to indicate the presence of a hazard that could cause minor or moderate personal injury or damage to your vehicle. To avoid or reduce the risk, the procedures must be followed carefully.



High Voltage Risk - The high voltage symbol is used on the vehicle to alert the operator of some high voltage components.



Arrows in an illustration that are similar to those above indicate movement or action.



Arrows in an illustration that are similar to those above call attention to an item in the illustration.

ROLLOVER WARNING

Some vehicles have a significantly higher rollover rate than other types of vehicles. This vehicle has a higher ground clearance and a higher center of gravity than many passenger vehicles. Driven in an unsafe manner, all vehicles can go out of control. Because of the higher center of gravity, if this vehicle is out of control, it may roll over when other vehicles may not.

Do not attempt sharp turns, abrupt maneuvers or other unsafe driving actions that can cause loss of vehicle control. Failure to operate this vehicle safely may result in a collision, rollover of the vehicle and severe or fatal injury. Drive carefully.

Failure to use the vehicles driver and passenger seat belts can cause severe or fatal injuries in an accident. In a rollover crash, an unbelted person is significantly more likely to die than a person wearing a seat belt. Always buckle up.

WARNING!

Failure to operate this vehicle in a safe and prudent manner may result in loss of control or an accident.

VEHICLE MODIFICATIONS / ALTERATIONS

WARNING!

Any modifications or alterations to this vehicle could seriously affect its road worthiness and safety and may lead to a collision resulting in serious injury or death.

Installing of Radio Transmitting Equipment

When installing a Citizen Band (CB) or ham radio in your vehicle, be sure to observe the following precautions; otherwise, the new equipment may adversely affect the Electric Vehicle (EV) control system and other electronic parts.

WARNING!

- A cellular phone should not be used while driving. Full attention must be given to vehicle operation. Some jurisdictions prohibit the use of cellular phones while driving.
- If you must make a call while your vehicle is in motion, the hands-free cellular phone operational mode is highly recommended. Exercise extreme caution at all times so full attention may be given to vehicle operation.
- If you are unable to devote full attention to vehicle operation while talking on the phone, pull off the road to a safe location and stop your vehicle.

CAUTION!

- Keep the antenna as far away as possible from the electronic control modules.
- Keep the antenna wire more than 8 inches (20 cm) away from the electronic control system harnesses. Do not route the antenna wire next to any harness.
- Adjust the antenna standing-wave ratio as recommended by the manufacturer.
- Connect the ground wire from the CB radio chassis to the body.

1

2

3

4

5

6

7

8

9

10

11

INTRODUCTION

GENERAL DISCLAIMER

Vehicle Product Warranty

Please refer to the “[Warranty Information p. 163](#)” information.

Scan the code below to access the Mullen Vehicle Center online. See the Warranty information available online by scanning the code below for Mullen warranties applicable to this vehicle and market.



If you have additional questions, reach out to your authorized Mullen Automotive Customer Solutions Support Team.

For service inquiries, email service@mullenusa.com or call.

Phone: (248) 988-4498

EXCEPT WHERE SPECIFICALLY REQUIRED BY LAW, THERE IS NO WARRANTY COVERAGE FOR THIS VEHICLE IF IT IS SOLD OR REGISTERED OUTSIDE OF THE UNITED STATES. The vehicle you are purchasing is configured for registration in the United States.

This policy does not apply to vehicles registered to US government officials or military personnel on assignments outside of the United States.

Service: Maintenance and Repairs

Your Mullen vehicle makes use of advanced materials and technologies that require suitable maintenance and repair work. Periodic maintenance ensures reliability, road safety and functional ability of the vehicle. Failure to maintain the vehicle according to the Mullen specifications or maintenance intervals could result in damage to the vehicle and negate the Mullen Warranty. Therefore, please have work performed by a Mullen authorized service provider with appropriately trained personnel.

NOTE:

- If service work is not performed according to Mullen repair and service instructions, subsequent damage and related safety hazards may occur.
- For service, maintenance, or inquiries, refer to the [Customer Assistance p. 162](#) chapter for contact information.

Parts and Accessories

It is recommended that you only use authorized Mullen parts and accessories for repair and service. Modifications made using unauthorized parts or accessories could negate the Mullen Warranty Policies and Procedures.

High-Voltage System Dangers

 **WARNING!**

- Mullen vehicles contain High Voltage Systems, comprised of Lithium Iron Phosphate Batteries, high voltage cables (400V), electric plug cables, and a low voltage (12V) battery.
- Attempting to service or repair high voltage equipment on your own could put you in danger of being electrocuted and suffering severe or fatal injuries. High voltage connections and cables are identified by orange color and identifying warning labels.
- Mullen strongly recommends that all service and repair work be done by a Mullen authorized service provider. Service and repair of high voltage systems or components should only be performed by specially trained technicians with related training and experience.

California Proposition 65

 **WARNING!**

- Operating, servicing and maintaining a passenger vehicle or off-highway motor vehicle can expose you to chemicals including phthalates and lead, which are known to the State of California to cause cancer and birth defects or other reproductive harm. To minimize exposure, wear gloves or wash your hands frequently when servicing your vehicle. For more information, go to: www.P65Warnings.ca.gov/passenger-vehicle.
- Battery posts, terminals, and related accessories contain lead and lead compounds. Wash hands after handling.

1

2

3

4

5

6

7

8

9

10

11

GRAPHICAL TABLE OF CONTENTS

FRONT VIEW	10
REAR VIEW	11
INSTRUMENT PANEL	12

1
2
3
4
5
6
7
8
9
10
11

GRAPHICAL TABLE OF CONTENTS



0101203566

FRONT VIEW

- | | |
|--|---------------------------------|
| 1. Exterior Mirrors | 5. Side Turn Signal |
| 2. Antenna | 6. Charging Port Door |
| 3. Low Beam/High Beam Headlights and Front Turn Signal | 7. Right High Voltage Batteries |
| 4. Fog Light | 8. Dual Rear Wheels |



0101203125

REAR VIEW

- 1. Spare Tire and Winch
- 2. Drive Motor
- 3. Cab Tilting Mechanisms

- 4. Charging Port Door
- 5. Rear Tow Hook
- 6. Backup Camera (if equipped)

1
2
3
4
5
6
7
8
9
10
11

GRAPHICAL TABLE OF CONTENTS

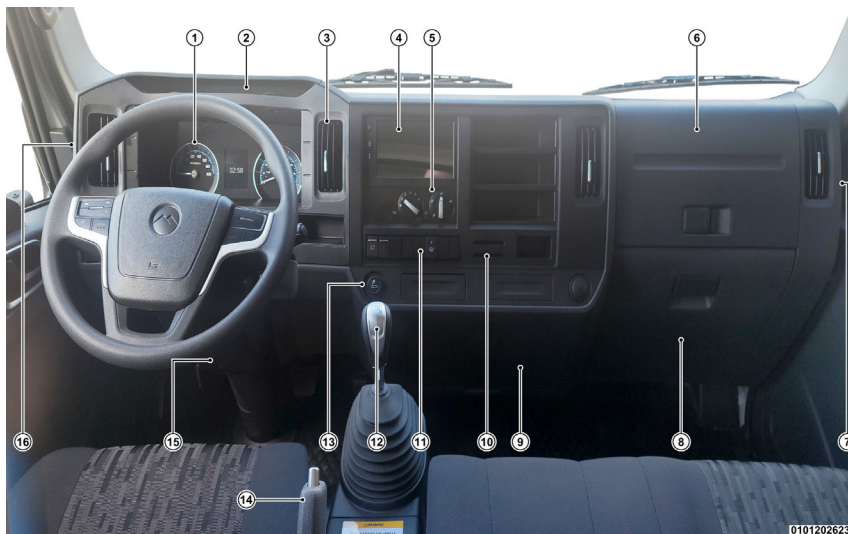

INSTRUMENT PANEL

- | | | | |
|-------------------------------|----------------------------------|--|-------------------------------------|
| 1. Instrument Cluster Display | 5. Climate Control | 9. Fuse Panel | 13. Cigarette Lighter |
| 2. Folder Compartment | 6. Upper Glove Compartment | 10. Card Storage Slots | 14. Parking Brake Lever |
| 3. Air Outlets | 7. Windshield Washer Fill Access | 11. Power Feature Switches (if equipped) | 15. Steering Wheel Adjustment Lever |
| 4. Touchscreen Radio | 8. Lower Glove Compartment | 12. Gear Shift Selector | 16. Brake Fluid Fill Access Cover |

GETTING TO KNOW YOUR VEHICLE

HIGH VOLTAGE SYSTEM COMPONENTS	14
High Voltage Batteries	16
HIGH VOLTAGE CHARGING OPERATION	18
Charging Port Door	18
E-Lock Actuator	19
Vehicle Charging	19
Maximizing High Voltage Battery Life	21
Battery Maintenance	22
KEYS	23
Types of Keys	23
Key Fob Functions	24
General Information	25
IGNITION SWITCH	26
Ignition Switch Positions	26
DOORS	27
Vehicle Door Locks	27
SEATS	29
Driver Seat Adjustment	29
Fold Flat Passenger Seats	30
STEERING WHEEL	31
Manual Tilt Steering Column Lever	31
Steering Wheel Radio Controls	32
Horn	33
MIRRORS	33
Exterior Side Mirrors	33

EXTERIOR LIGHTS	34
Multifunction Headlight Control Lever	34
Front Exterior Lights	35
INTERIOR LIGHTS	36
Dome Light	36
Interior Brightness Control	37
WINDSHIELD WIPERS AND WASHERS	38
Windshield Wiper And Washer Lever	38
WINDOWS	39
Power Windows	39
ANTENNA	40
Antenna	40
INTERNAL FEATURES	41
Interior Storage	41
Cup Holders	42
Sun Visor	42
Cigarette Lighter And Ashtray	43

1

2

3

4

5

6

7

8

9

10

11

GETTING TO KNOW YOUR VEHICLE



HIGH VOLTAGE SYSTEM COMPONENTS

High Voltage Battery System

The high voltage cables and components are orange for easier identification.



This symbol is used to inform you of an operation which will result in serious injury or death if instructions are not followed. This symbol is present on the vehicle indicating some of the high voltage components.

 DANGER	
	HIGH VOLTAGE You will be severely injured or killed if you do not follow the correct procedure. Components marked with High Voltage Warning should be avoided. Service must be performed by qualified personnel only. See owner's manual for correct procedure.
<small>AGID 301X-AB 0101201454</small>	

WARNING!

- Your vehicle contains sealed Lithium Iron Phosphate high voltage batteries. If the Lithium Iron Phosphate batteries are disposed of improperly; there is a risk of severe burns and electrical shock that may result in serious injury or death and there is also a risk of environmental damage.
- The Electric Vehicle (EV) system uses high voltage. The system can be hot to touch during and after starting and when the vehicle is shut off. Be careful of both the high voltage and the high temperature. Follow the warning labels that are attached to the vehicle.
- Never disassemble, remove or replace high voltage parts and cables as well as their connectors because they can cause severe burns or electric shock that may result in serious injury or death. The vehicle's high voltage system has no user serviceable parts.
- The drive motor and drive motor cables are high voltage elements and must be serviced by professionals to avoid damage, serious injury, or death.
- High voltage battery cables and battery assembly are high voltage elements and must be serviced by an authorized Mullen service center for any service or performance issues.

NOTE:

For service, maintenance, or inquiries, refer to the [Customer Assistance p. 162](#) chapter for contact information.

The high voltage system components consist of the following:

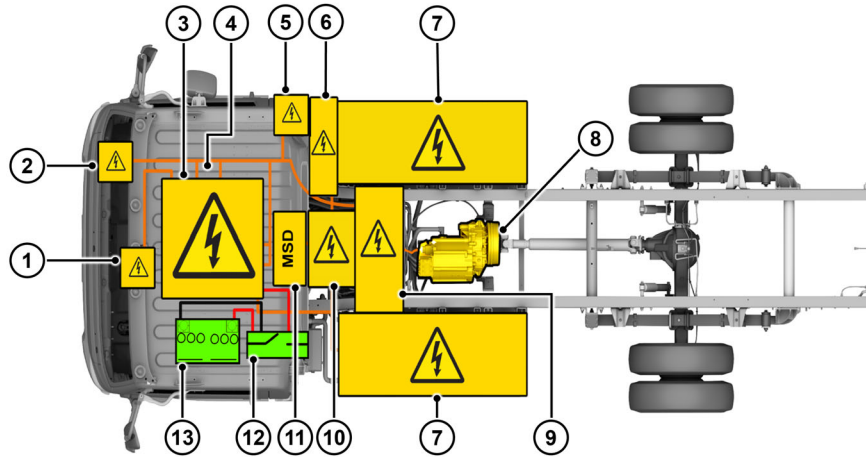

- 1. Positive Temperature Coefficient Heater (PTC)
 - 2. Air Conditioning Compressor (AC)
 - 3. Electro-Hydraulic Power Steering Pump (located beneath 4-in-1)
 - 4. Auxiliary Drive System (4-in-1)
- Black = 12-Volt (Negative) Cables

- 5. Inlet Charging Port
 - 6. High Voltage Battery Heater
 - 7. High Voltage Battery (2 on each side)
 - 8. High Voltage Drive Motor
- Red = 12-Volt (Positive) Cables

- 9. On Board Charger (OBD)
 - 10. Battery Disconnect Unit (BDU)
 - 11. Manual Service Disconnect (MSD)
 - 12. 12-Volt Manual Battery Disconnect Switch
 - 13. 12-Volt Battery
- Orange = High Voltage Cables

1
2
3
4
5
6
7
8
9
10
11



0101203567

High Voltage Battery Locations

High Voltage Batteries

Your vehicle is equipped with four Lithium Iron Phosphate rechargeable batteries that are used to power the electric powertrain systems.

The high voltage batteries are located between the front and rear tires, along the frame rails, on both sides of the vehicle. The high voltage batteries are maintenance-free and designed to last for the life of the vehicle.

The vehicle must be plugged in for the Lithium Iron Phosphate batteries to charge.

WARNING!

In case of a collision:

- If your vehicle is drivable, pull your vehicle off the road, shift into the NEUTRAL (N) position, securely engage the parking brake by pulling up on the parking brake lever, (the parking brake lever is located to the right of the driver's seat) and turn the vehicle off.
- Check your vehicle to see if there are exposed high voltage parts or cables. To avoid personal injury, never touch high voltage wiring, connectors, and other high voltage parts, such as the inverter unit and the Lithium Iron Phosphate batteries. Never make contact with bare electrical wires. If exposed electric wires can be seen from inside or outside of your vehicle, they could cause an electric shock.
- If the vehicle receives a strong impact to the floor while driving, stop the vehicle in a safe location and check the floor.
- Leaks or damage to the Lithium Iron Phosphate batteries may result in a fire. If you discover a leak, contact emergency services immediately. Since the fluid leak may be lithium manganate from the Lithium Iron Phosphate batteries, never touch the fluid leak inside or outside the vehicle. If the fluid contacts your skin or eyes, wash it off immediately with a large amount of water and receive immediate medical attention to help avoid serious injury.

WARNING! (Continued)

- If a fire occurs in the vehicle, leave the vehicle as soon as possible. Only use a type ABC, BC, or C fire extinguisher that is meant for use on electrical fires. Using an incorrect fire extinguisher and/or a small amount of water can result in serious injury or death from electrical shock.
- If you are unable to safely assess the vehicle due to vehicle damage, do not touch the vehicle. Leave the vehicle and contact emergency services. Advise first responders that this is an electric vehicle.

1

2

3

4

5

6

7

8

9

10

11

GETTING TO KNOW YOUR VEHICLE

HIGH VOLTAGE CHARGING OPERATION

Charging Port Door

The charging port door is located on the passenger side of the vehicle. It is located between the cab and the high voltage batteries.

The charging system consists of the following:

- Power outlet
- Fast charging high voltage power cable
- Fast charging high voltage Power cable plug

CAUTION!

The access end of the Alternating Current (AC) charging power supply line must be equipped with a 20 amp (A) circuit breaker and be grounded. Do not move the vehicle during charging. Do not use extension cords with the charging cable. Only use cables provided by Mullen.

WARNING!

Damage to the charging port may affect the ability to charge the vehicle and may create an unsafe condition. Please have the vehicle serviced immediately at a Mullen authorized service provider.

NOTE:

For service, maintenance, or inquiries, refer to the [Customer Assistance p. 162](#) chapter for contact information.

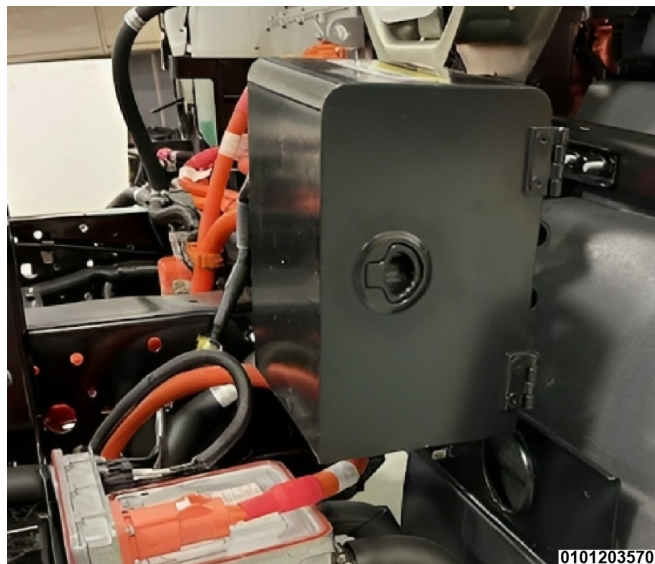

To open the charging port door, pull the ring handle.

E-Lock Actuator

The charging port on the vehicle includes an E-Lock actuator. When charging at a public charging facility, the E-Lock actuator is a security feature intended to safeguard the charging process with a locking mechanism that locks the charging station connector plug into the charging inlet on the vehicle. The actuator prevents the charger from being removed during the charging process and ensures that only authorized users can disconnect the charging cable from the charging station.

The user will activate the actuator through the charging station's user interface when plugging into the charging port on the vehicle. After connecting the charger into the charging port, the E-Lock actuator will automatically secure the charging gun to the charging port of the vehicle.

If the charging process needs to be interrupted before the vehicle has finished charging, you can interrupt safely through the charging station interface. Example: "Stop" or "End Charging" button. When stopping the session, the station will discontinue power supply to the vehicle, ensuring safe disconnection.

When charging the vehicle using a portable charger, or in a garage environment, the user can disengage E-Lock by turning off the main power supply on the vehicle. We recommend the removal of the E-Lock and secure placement of it alongside the connectors near the charging box. This flexibility allows for convenient and safe charging outside of public charging station controlled environments.

Vehicle Charging

The amount of battery life remaining in the vehicle can be determined by checking the State of Charge (SOC) in the instrument cluster. If you want to charge the vehicle to maintain optimum performance, the vehicle must be fully charged using a US-specified charger in accordance with

relevant national rules and regulations as stipulated in the charger manufacturer's operation instructions.

NOTE:

The Master Switch must be left ON when charging the vehicle.

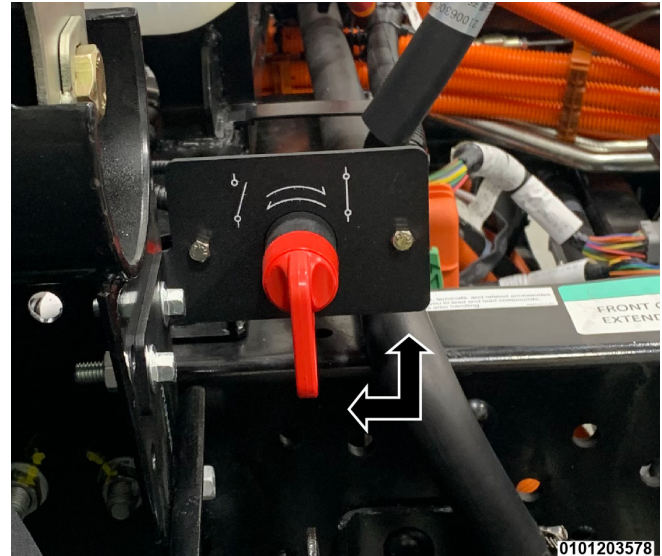

Master Switch (shown in ON position)

1

2

3

4

5

6

7

8

9

10

11

GETTING TO KNOW YOUR VEHICLE

⚠ CAUTION!

During the charging process, pay special attention to the following:

- Although the charger is equipped with safety measures, and can be left unattended while charging, accidents can happen if the charger is not used as it is designed. Make sure to read and follow charge manufacturer's operating instructions.
- Verify the charger is the correct charger for your vehicle, verify cables and charging port are not damaged before charging.
- Do not charge the vehicle if you or any charging components are wet. Keep your hands dry. During the vehicle charging process, avoid getting the charger, connecting cable and charger interface wet.
- If fault information is displayed during the charging process, reach out to a Mullen authorized service provider.
- If abnormal conditions exist in charging process, the charging operation shall be terminated immediately and power source of charging device shall be disconnected.
- When low-temperature charging, if minimum temperature of the unit cell is lower than 0 degrees Celsius, do not allow battery SOC to be less than 20% to ensure enough remaining electric quantity of high voltage battery for pre-heating. When inserting the charger, the high voltage battery will use remaining SOC to pre-heat unit cells. Charging process can only be started when the temperature of unit cell is higher than 0 degrees Celsius.

⚠ NOTE:

For service, maintenance, or inquiries, refer to the [Customer Assistance p. 162](#) chapter for contact information.

Charging Steps



The Charging Plug Connection Light will be illuminated in the instrument cluster display when a plug is connected to the vehicles charging port and high voltage batteries are charging.

Charging Plug Connection Light

DC Charging

1. Confirm that no fault information is displayed in the instrument cluster display.
2. Apply the parking brake and shift vehicle into NEUTRAL (N) gear.
3. Verify the ignition key is turned OFF and remove the key.
4. Insert the DC charger into DC charging port.



Charging Port

5. Rotate the key in the ignition to the ON position and check the charging status information and battery information on instrument cluster display.
6. After charging is finished and the State Of Charge (SOC) equals 100%, the charging process will stop automatically.

NOTE:

If the State Of Charge (SOC) is less than 100% and the charging process is terminated before reaching full charge. Turn off the DC charger before removing it from the vehicle.

7. Vehicle charging is completed.

WARNING!

- When charging, keep away from flammable and explosive articles to avoid accidents or fires.
- Vehicle should not be unaccompanied while charging.

Maximizing High Voltage Battery Life

The optimum battery operating range State of Charge (SOC) for the high voltage batteries is 25-85%. Maintaining the State of Charge (SOC) between 25-85% will help improve the longevity of the high voltage batteries.

Charge the high voltage batteries immediately if the SOC is below 20%. If the battery level drops below 20%, the SOC will display the remaining percentage of charge in red and the “Low State Of Charge” yellow warning light will flash in the instrument cluster display.

1

2

3

4

5

6

7

8

9

10

11

GETTING TO KNOW YOUR VEHICLE



Low Charging Status Indicator

If the indicator light comes on and begins to flash, it means that the electric quantity of the high voltage battery is below 20% and the vehicle will run under limited power to enable locating the closest charging station. The vehicle will need to be charged as soon as possible.

Driving with SOC below 20% will also reduce acceleration, torque and the maximum speed. Driving repeatedly with a SOC below 20% will result in decreased battery performance and life.

When not in use, the vehicle should be stored in temperatures between 32°F (0°C) and 113°F (45°C). If the vehicle will be parked for an extended period (approximately 30 days or more), set the maximum state of charge at 50%.

NOTE:

If the vehicle is left unplugged, the vehicle will use energy from the high voltage battery to recharge the 12V battery when needed.

Battery Maintenance

1. Normal vehicle application requirements:
 - Do not charge vehicle more than once per day.
 - Perform “Battery Maintenance Procedure” listed below, once per year to avoid battery damage.
 - The electric vehicle battery should be fully charged at least once in every three days.
2. Requirements on vehicles left unused for more than a week:
 - The optimal battery State Of Charge (SOC) range for battery storage is between 40%-80%.
 - Storage environment of the vehicle needs to be ventilated, dry, and free from direct sunshine, rain, and heat.
 - Perform “Battery Maintenance Procedure” once every three months to avoid battery damage.
 - If the vehicle has sat unused for a long period of time, perform the “Battery Maintenance Procedure” before driving to restore best battery performance.

Battery maintenance procedure:

1. Drive the vehicle to drain the battery State Of Charge (SOC) until the battery capacity is within the range of 25%-40%.
2. Bring the vehicle to a stop and turn off the power by rotating the key back to the LOCK position. Then start up the power by rotating the key to the START/ON position and turn off the vehicle accessories.
3. Leave the vehicle in the ON position for 12-15 hours (during this period of time, do not use the vehicle or any electrical equipment).
4. After the vehicle has sat in the ON position 12-15 hours, you will need to completely charge the vehicle to 100% SOC before driving.
5. Battery maintenance procedure is now completed.

KEYS

Types of Keys

Your vehicle can come equipped with two different types of keys.

The two types of keys are as follows:

- **Common Door/Ignition Key** — This key can lock/unlock the doors and start the vehicle.
- **Common Key with Key Fob (If Equipped)** — This key can lock/unlock the doors by using the key or remotely by using the key fob. This key can also start the vehicle.



Common Door/Ignition Key

1
2
3
4
5
6
7
8
9
10
11



0101200713

Common Key with Key Fob (If Equipped)

1. Common Key (Ignition/Door Key)
2. Doors Lock
3. Doors Unlock

⚠ WARNING!

- When leaving the vehicle, please take the keys along with you to avoid any accident caused by vehicle start or improper operation by others.
- Please store keys in a secure location. If a key/key fob is lost or needs to be duplicated, reach out to a Mullen authorized service provider.

⚠ NOTE:

If replacement keys are needed, refer to the [Customer Assistance p. 162](#) chapter for contact information. Any privately made keys will not work with the vehicle.

Key Fob Functions

Locking and Unlocking with Key Fob:

1. Press the lock button on the key fob to lock the vehicle:
 - When the vehicle is locked successfully, the exterior lights will flash once.
 - If the vehicle is not locked successfully, the lights will flash continuously and the alarm will sound. Turn off the alarm by pressing the unlock button on the key fob twice within 2 seconds to terminate the anti-theft alarm. The operator will need to make sure that all vehicle doors are closed and secured properly before locking.
2. Press the unlock button on the remote key fob to unlock the vehicle, all turn signal lights will flash twice to indicate that the vehicle is unlocked.

3. Press and hold the lock button on the key fob and the doors will lock and the windows will go up, as long as the button on the key fob is pressed. Press and hold the unlock button on the key fob and the doors will unlock and the windows will express down.

Vehicle anti-theft status:

1. When the vehicle anti-theft status is activated, and the doors are opened or the starting key is turned to the ON position, all turn signal lights will flash and the horn will sound repeatedly when either door is opened.
2. When the system sounds an alarm, press the unlock button on the key fob twice within two seconds to terminate the anti-theft alarm.
3. Key fob operation distance: Depending on the life of the battery in the key fob, the remote control unit will operate within an approximate range of 100 feet (30 meters) of the vehicle's cab.

Care of the Key Fob

The remote control key fob is an electronic component. The following precautions should be taken to prevent damage to the key fob:

- Do not place the key fob in high-temperature environment.
- Do not disassemble the remote control unit.
- Be careful not to drop the remote control unit.
- Avoid water or liquids coming into contact with the key fob.

If the remote key cannot function within the normal range or the indicator light on key fob is rapidly flashing, the following measures should be taken:

- Radio interference is a possible cause if the key fobs stop operating all of a sudden. Wireless devices such as radar detectors and anti-theft alarms can interfere with the key fob signals by transmitting at the same frequency.
- Check if the battery capacity in remote control key fob is sufficient.

To replace the key fob battery, do the following:

- Use CR2032 lithium battery.
- When replacing batteries, be careful to not lose other components and parts.
- Dispose of the used batteries in an environment-friendly manner.

WARNING!

Make sure that children do not have access to the batteries when removed from the key fob, so that they do not accidentally swallow the batteries or components and parts of the remote control unit which could result in death!

General Information

The following regulatory statement applies to all radio frequency (RF) devices equipped in this vehicle.

This device complies with Part 15 of the FCC Rules and RSS standard(s).

The key fob FCC ID: 2BCFM-KEY5722.

Unintentional Radiators:

- RKE Receiver (Remote Keyless Entry)

Operation is subject to the following two conditions:

1. This device may not cause harmful interference, and
2. This device must accept any interference received, including interference that may cause undesired operation.

NOTE:

Changes or modifications not expressly approved by the party responsible for compliance could void the user's authority to operate the equipment.

1

2

3

4

5

6

7

8

9

10

11

GETTING TO KNOW YOUR VEHICLE

IGNITION SWITCH

Ignition Switch Positions

The ignition switch is used to control the systems power supply for startup, ignition, charging, and instrument controls.



LOCK — The key can be inserted and removed from this position. You can cycle the key from the lock position through the other positions.

ACC — This position will turn on some of the electronics, such as the radio.

ON — Turning the key to this position will turn on the Instrument Cluster Display and electrical units.

START — Turning the key to this position will start the high voltage batteries. Turn the key to the start position briefly and release and the key will go to the ON position to drive the vehicle.

NOTE:

It is not recommended to leave the vehicle for long periods of time in the ACC position. Doing so will drain the vehicle batteries.

WARNING!

When the vehicle is moving, do not rotate or pull out the key. The steering wheel will lock up and cause a serious accident.

DOORS

Vehicle Door Locks



Key Placement

Open, close and locking the doors

WARNING!

Driving with the door at a half-closed position is very dangerous. Please check to make sure all vehicle doors are closed before driving.

Insert the key into the keyhole.

The drivers door lock mechanism locks and unlocks both doors. When locking/unlocking from the driver door, rotate the key to the front of the vehicle to lock both doors, or to the back of the vehicle to unlock both doors.

The passenger door lock mechanism only locks or unlocks the passenger door. When locking/unlocking from the passenger door, rotate the key to the front of the vehicle to lock the passenger door, or to the back of the vehicle to unlock that door.

Pull on the lower part of the door handle to open the door.

1

2

3

4

5

6

7

8

9

10

11

GETTING TO KNOW YOUR VEHICLE

Opening the door from the inside.



Interior Door Lock/Unlock

The interior door lock on the driver side will lock or unlock both doors. The interior door lock on the passenger side can only lock or unlock the passenger door.

Push the door lock lever in to lock the door. Pull the door lock lever out to unlock the door. When the door is unlocked, pull on the door handle to open the door.

WARNING!

- When the vehicle is running, lock the vehicle for safety and to avoid a door accidentally opening. Do not drive the vehicle unless both doors are securely closed.
- When the driver and passengers are exiting the vehicle, make sure the doors are closed securely, and turn the key to lock both the driver and passenger's side doors.

SEATS

Driver Seat Adjustment

Forward/Rearward Adjustment Lever — Driver side only

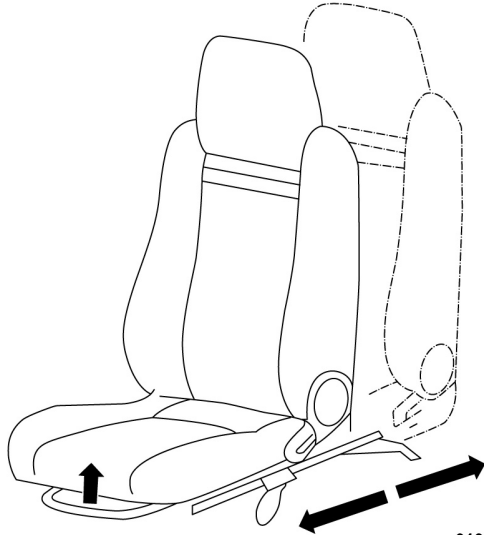

0101201388

Pull up on the bar under the front seat to release the slide mechanism so the seat can slide backward or forward. Release the bar after reaching the desired position so that the seat base will lock into position securely.

The seats can slide forward and rearward to adjust the seat to properly operate the brake and accelerator pedals.

Seat Back Adjustment

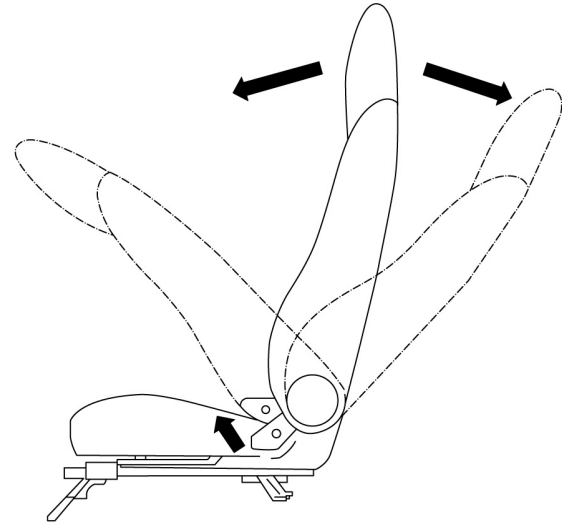

0101201386

To adjust the seat back, pull up on the lever at the outside edge of the seat base. Release the lever handle once the desired angle is reached. Make sure that the seat position is secured in place.

1

2

3

4

5

6

7

8

9

10

11

GETTING TO KNOW YOUR VEHICLE

Fold Flat Passenger Seats

Center Seat Fold Flat



Pull the lever on the side of the center seat back, to fold the center seat back down flat. The back of the center seating position has cup holders when the seat back is folded flat. To raise the center seat back, lift up on the lever and fold the seat back to the upright position until it is secured in place.

Outboard Seat Fold Flat



To fold the outboard passenger seat flat, pull the lever on the outside edge of the seat back. To raise the outboard seat back, lift up on the lever and fold the seat back to the upright position and secured in place.

STEERING WHEEL

Manual Tilt Steering Column Lever

The steering wheel can be adjusted up or down for driving comfort.



⚠ WARNING!

To prevent injury or death from a vehicle collision. Do not adjust the steering wheel while driving.

The steering wheel can be adjusted using the following steps:

1. When sitting in the driver seat with the vehicle in Neutral (N) and the parking brake engaged securely. Pull the release lever on the bottom left of the steering column toward you to release the steering wheel setting.
2. Adjust the steering wheel to the desired height.
3. Push the lever down and away, toward the base of the steering column, to secure the steering wheel adjustment in place.

1

2

3

4

5

6

7

8

9

10

11

GETTING TO KNOW YOUR VEHICLE

Steering Wheel Radio Controls

The left side of the steering wheel is equipped with radio controls.

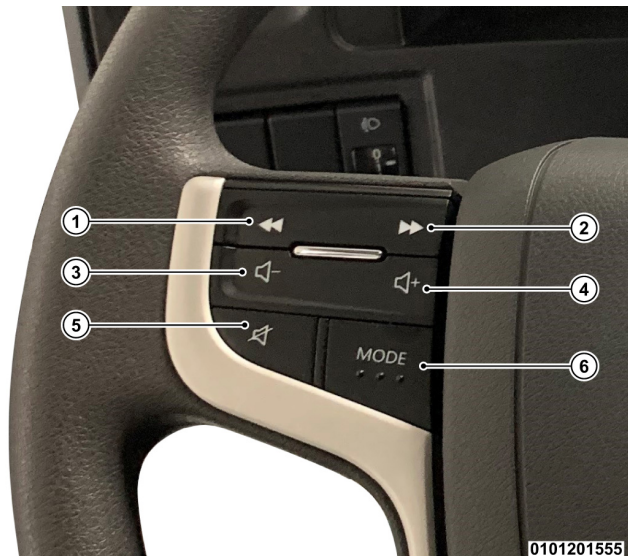

Steering wheel radio control functions include:

- | | |
|----------------|--------------|
| 1. Seek Down | 2. Seek Up |
| 3. Volume Down | 4. Volume Up |
| 5. Mute | 6. Mode |

Seek: Press the seek up or seek down button to search radio stations up and down the frequency dial. You can also hold and quickly release to search for the next radio station with reception. If using USB, briefly press the button to skip to the previous or next file.

Volume: Press the button on the left side (-) to decrease the volume, or on the right side (+) to increase the volume.

Mute: The Mute button will silence the radio.

MODE: The Mode button can cycle through radio or USB selections, and if your vehicle is paired to a cellular device, you can cycle through, media, and bluetooth modes on your playlist.

Horn

The steering wheel is equipped with a horn. Press on or near the horn symbol on the center of the steering wheel pad and the horn will sound.



MIRRORS

Exterior Side Mirrors

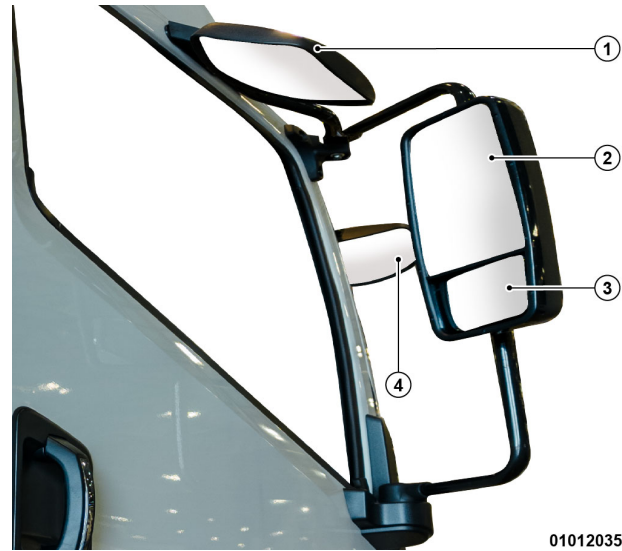

Side Mirrors

- | | |
|-------------------------|---|
| 1. Wide-angle Side Lens | 3. Blind Spot Mirror |
| 2. Main Side Mirror | 4. Overhead Blind Spot Mirror (if equipped) |

The external side mirrors can be adjusted manually up, down, left, and right.

1
2
3
4
5
6
7
8
9
10
11

GETTING TO KNOW YOUR VEHICLE

EXTERIOR LIGHTS

Multifunction Headlight Control Lever

The multifunction headlight control lever is located behind the left side of the steering wheel. This lever controls the vehicles lights and integrates with the TRIP button functions.

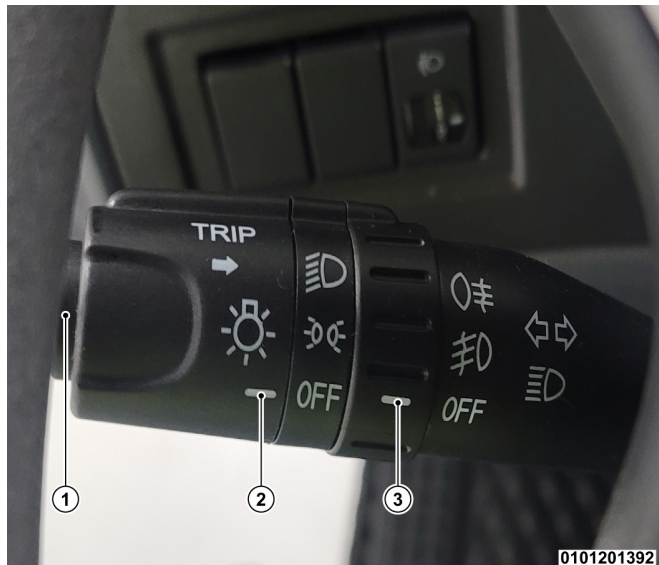

1. TRIP
2. Parking/Daytime Running/Headlight switch
3. Fog Light Switch

TRIP button functions

To change screens through the instrument cluster display, push the TRIP button on the end of the lever. Push it repeatedly to cycle through the information screens. Or press and hold, to change functions within a screen.

Parking/Daytime Running/ Low Beam Headlights

Rotate the outer ring to the first position to turn on the parking/daytime running lights, rotate it again to turn on the low beam headlights. Rotate the switch to the OFF position to turn off all of the vehicle lights.

Fog Light Adjustment

The parking lights must be on for fog lights to activate. When the parking lights are on, rotate the fog light switch to the second position to activate the fog lights. The third position is for rear fog lights (rear fog lights disabled). To turn off the fog lights rotate the dial to the OFF position or rotate the parking lights dial to OFF.

High and Low Beam Adjustment

With the low beam headlights on, pull the handle and release quickly to flash the high beam lights. The high beams will automatically resume to low beam position after being released. To leave the high beam headlights on continuously, push the handle away.

⚠ NOTE:

Make sure to turn off high beam headlights when another vehicle is approaching. Using the low beam headlights when approaching other drivers can prevent temporarily blinding oncoming drivers.

Turn Signals

Pull down on the handle to activate the left turn signal. Push up the handle to activate the right turn signal.

⚠ NOTE:

When completing a turn, the turn signal will automatically turn off when the steering wheel is straightened. The control handle will automatically return and the direction indicator lamp will turn off.

Front Exterior Lights

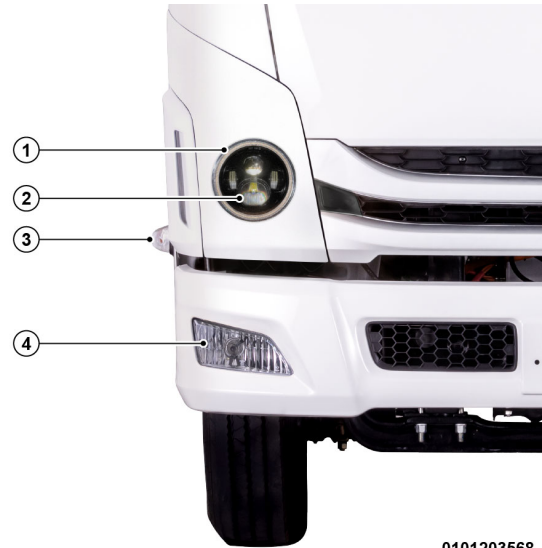

0101203568

1. Front Turn Signal Light/Running Light
2. Head Light (High/Low Beam)
3. Side Turn Signal Light
4. Front Fog Light

GETTING TO KNOW YOUR VEHICLE

INTERIOR LIGHTS

Dome Light



1. Dome light turns on when doors are open.
2. Dome light is Off
3. Dome light is On

To turn on the dome light when doors are opened, slide the switch fully to the left. To turn the dome light off, slide the switch to the middle position. To turn the dome light on, set the switch fully to the right.

NOTE:

- If the key is turned to the ON position and the door is left open, the interior dome light will turn off after ten minutes to save power. If the door is closed in this ten minutes, the interior dome light will immediately turn off. If the key is NOT in the ON position and the door is open, the interior dome light will turn off after ten minutes to save power. If door closes in the ten minute time frame, the interior dome light will turn off in 30 seconds.
- Rotate the key to the ON position in the 30 second time frame or use the mechanical key or the remote key to lock the vehicle. The interior dome light will turn off.

Interior Brightness Control

The interior brightness control can be found in the instrument panel switches to the right of the steering wheel.



When the headlights are on, the brightness of the radio, instrument panel switches, steering wheel controls, and climate control dials can be adjusted. Press it once for brighter, press it again for dimmer.

NOTE:

To adjust the brightness of the instrument panel display, use the TRIP button on the end of the multifunction headlight control lever on the left side of the steering wheel.

1

2

3

4

5

6

7

8

9

10

11

GETTING TO KNOW YOUR VEHICLE

WINDSHIELD WIPERS AND WASHERS

Windshield Wiper And Washer Lever

The windshield wiper control lever is located behind the right side of the steering wheel. Your vehicle is equipped with two front windshield wiper blades with nozzles for windshield washer fluid to be sprayed onto the windshield.

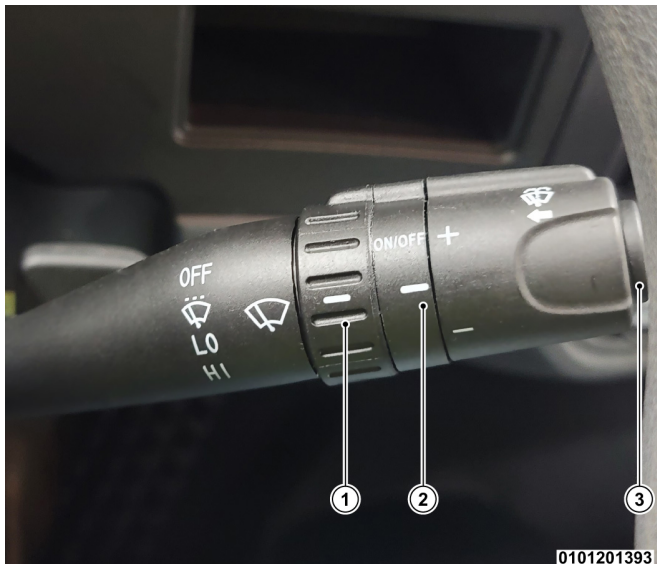

1. Wiper speed, OFF, intermittent, LO, HI
2. Intermittent wiper speed, faster + or slower –
3. Windshield washer fluid spray

Wiper Speed

Lever positions:

- The first position, the windshield wiper will work intermittently (the + or – on the second ring adjusts the intermittent speed). Push the lever down to the second position for lo and again for high speed.
- The second position (LO) and the windshield wiper will operate at low speed.
- The third position (HI) and the windshield wiper will operate at high speed.

Windshield Washer Button

To wash the windshield, press the washer fluid button at the end of the wiper lever. The nozzles will spray windshield washer fluid on the window and the wipers will make two passes over the windshield. Release the button and the wipers will stop.

! NOTE:

- Do not turn on the windshield wipers when the windshield is dry. If the windshield is dry, use the washer fluid.
- The windshield washer will spray windshield washing solution on the windshield. Do not hold the washer fluid button for more than five seconds to avoid wear on the wiper mechanisms.

WINDOWS

Power Windows



The driver's and passenger's side windows can both be opened or closed from the dual switches on the driver's door. The passenger can open or close their window using the single switch on the passenger side.

Press the button to put the window down, pull the button up to raise the window. The button must be pulled up to raise the windows, but can be pressed down by pressing and releasing the window switch.

The power windows will not lower all the way into the door. About 75% of the total window will lower into the door.

The power windows can also be operated with the key fob. Press and hold the lock button on the key fob and the doors will lock and the windows will go up, as long as the button on the key fob is pressed. Press and hold the unlock button on the key fob and the doors will unlock and the windows will express down.

1
2
3
4
5
6
7
8
9
10
11

GETTING TO KNOW YOUR VEHICLE

ANTENNA

Antenna

The vehicle is equipped with an overhead infinitely variable control type antenna. The antenna is already adjusted properly from the manufacturer.

⚠ NOTE:

The antenna can be folded down or up if needed. Use care when folding or raising the antenna to not damage the antenna or wind deflector on top of the cab.



INTERNAL FEATURES

Interior Storage

Door Pockets

The door panel has various places for storage on both sides of the vehicle.

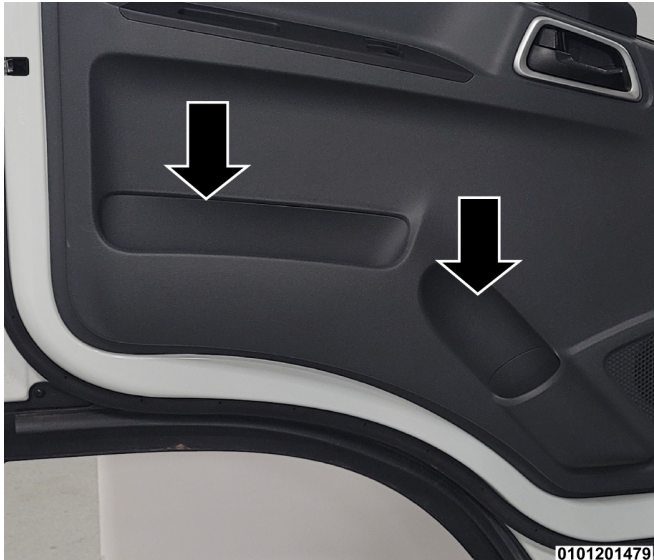

Upper and Lower Glove box

The upper and lower glove box can be found directly in front of the passengers seat of the instrument panel.

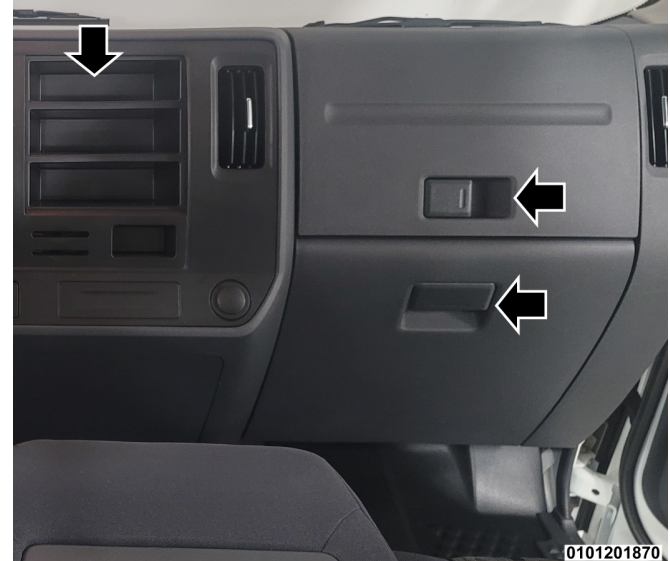

There are also several storage spaces along the instrument panel. A narrow space directly behind the steering wheel and various compartments for smaller or larger items.

1

2

3

4

5

6

7

8

9

10

11

GETTING TO KNOW YOUR VEHICLE

Cup Holders

The vehicle comes with two cup holders on the back of the center seating position. The cup holders are only accessible when the center seat is folded down. See “[Fold Flat Passenger Seats p. 30](#)” for information about folding the center seat back.



⚠ WARNING!

Avoid abrupt starting and braking when the cup holder is being used to prevent spilling the drink. If the liquid is hot, it can scald you or your passenger.

⚠ CAUTION!

Use only soft cups in the cup holder. Hard objects can injure you in an accident.

Sun Visor

Your vehicle is equipped with two sun visors. One is for the driver's side and the other is for the passenger's side.

Adjust the sun visor by pulling the edge down and adjusting the angle to where the sun visor is blocking the sun light. To adjust the sun visor to the side, pull the sun visor out of the hook and rotate toward the side window, and adjust to optimal position.

⚠ NOTE:

The sun visor should be adjusted so that it is not obstructing the driver's view.

Cigarette Lighter And Ashtray



The cigarette lighter is located in the instrument panel to the right of the steering wheel and next to the ashtray. To activate the cigarette lighter, push in on the warming socket of the cigarette lighter in the instrument panel. When the socket is heated it will automatically pop up from the depressed position, the surface of hot lighter will be red. When it is red, it is hot and ready for use.

The ashtray can be found to the right of the cigarette lighter. Pushing the ashtray in, will pop the tray out. Then the ashtray can be slid out further for use.

WARNING!

- Once the cigarette lighter is depressed, do not continue to press the cigarette lighter or the cigarette lighter will become excessively hot. This could cause a fire!
- Do not leave the cab when the cigarette lighter is activated, or a fire could start due to an excessively hot cigarette lighter!
- If the cigarette lighter socket is used for charging, the electrical load should not be greater than 100W, or circuit overload and other serious consequences will be caused!
- DO NOT touch the center or outer rim of the cigarette lighter as you could get burned. Only hold the cigarette lighter by the black handle end of the lighter.

1
2
3
4
5
6
7
8
9
10
11

INSTRUMENT CLUSTER DISPLAY	46	TOUCHSCREEN DISPLAY RADIO	58
Instrument Cluster Features	46	Radio Introduction	58
Digital Cluster System Information	48	Bluetooth®	59
WARNING LIGHTS AND MESSAGES	53	Phone Mode	61
Anti-Lock Brake (ABS) Warning Light	53	Radio Mode	63
Driving Power Limited Light	53	Media Mode	64
Electronic Power Steering Light	54	Radio Settings	68
Low Charging Status Light	54	TELEMATICS	73
Rear Fog Lights	54	Telematics Getting Started	74
Anti-Theft Light	54	Telematics General Information	74
Brake System Indicator Light	55	CLIMATE CONTROLS	75
High Voltage Battery Fault Light	55	Climate Control Overview	75
Charging Plug Connection Light	55	Fan Speed Dial	75
Drive Motor Fault Light	55	Mode Control Dial	76
Electronic Brake Distribution (EBD) - Light	56	A/C (Air Conditioner) Button	77
Hazard Lights	56	Recirculation Button	77
Parking Brake Light	56	Heat Button	77
Seat Belt Reminder Light	56		
Vehicle Disable Indicator	57		
Front Fog Light	57		
Parking/Headlights Indicator Light	57		
READY Light	57		
Turn Indicator Lights	57		
High Beams Indicator	57		

1
2
3
4
5
6
7
8
9
10
11

INSTRUMENTS AND CONTROLS

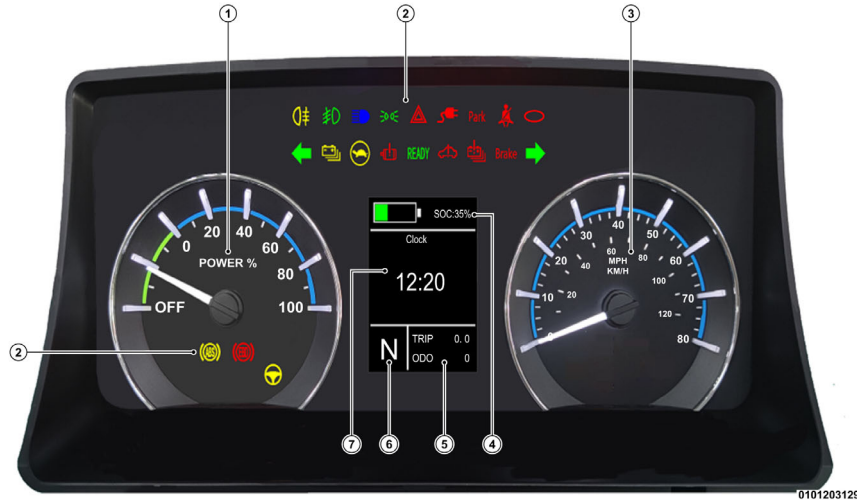

INSTRUMENT CLUSTER DISPLAY

Instrument Cluster Features

- | | | |
|-------------------------------------|--------------------------|-------------------------------|
| 1. High Voltage Battery Power Meter | 3. Speedometer | 5. Trip-odometer and Odometer |
| 2. Warning Lights and Indicators | 4. State Of Charge (SOC) | 6. Gear Shift Position |
| | | 7. General Message Display |

NOTE:

When the vehicle is turned on, the onboard diagnostic interface will briefly display the warning lights and indicators.

GAUGES

- **Power % Usage** — This gauge displays the percentage of battery usage during acceleration, deceleration, or steady driving.
- **Speedometer** — Speedometer indicates speed per hour of a moving vehicle. The speedometer can be set to mph or km/h depending on your preference in the message center.

NOTE:

To preserve the life of the batteries, do not run the motor when the battery levels are red in the cluster.

MESSAGE CENTER

- **State of Charge (SOC)** — Indicates the battery life remaining. If the battery level drops below 20%, the SOC bar will show remaining percentage in red and “Low State Of Charge” warning light may flash in the instrument cluster display.
- **Trip** — Trip mileage.
- **Odometer** — Vehicle mileage.
- **Current Gear** — Shows the current gear shift position, DRIVE (D), NEUTRAL (N), or REVERSE (R).
- **General Message** — General messages are displayed to suggest optimal operation. Such as “Please engage gear N”.

To change screens through the interface, push the TRIP button on the end of the multifunction lever on the left side of the steering wheel. Push it repeatedly to cycle through the information screens.

The Instrument Cluster Display includes the following vehicle status information:

- EV Motor Information
- Message Center Display
- State of Charge
- 12V Battery Voltage Meter
- Trip Odometer
- Backlight Setting
- English/Metric Selection
- EV Batteries Voltage and Current Meter
- EV Range
- Clock
- Door Status

NOTE:

Under normal display operation, when the perimeter lights are on, the backlight of the instrument panel display will also be on. The brightness of the radio and instrument cluster display will also be reduced if the vehicle is operating under reduced battery power.

1
2
3
4
5
6
7
8
9
10
11

INSTRUMENTS AND CONTROLS

Digital Cluster System Information

General messages can be displayed and switched by pushing the TRIP button on the end of the multifunction lever switch. Press the TRIP button to cycle through the cluster information display screens, or press and hold, to change functions within a screen.

EV Motor Information

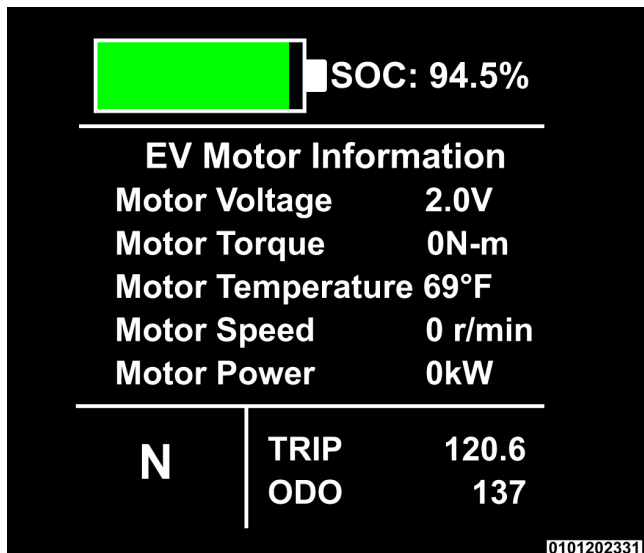

The EV Motor Information screen provides detailed information on the running status of the drive motor and high voltage batteries.

Message Center Screen



The digital message center delivers messages to the vehicle, such as "Please engage gear N".

Low Voltage Battery Status

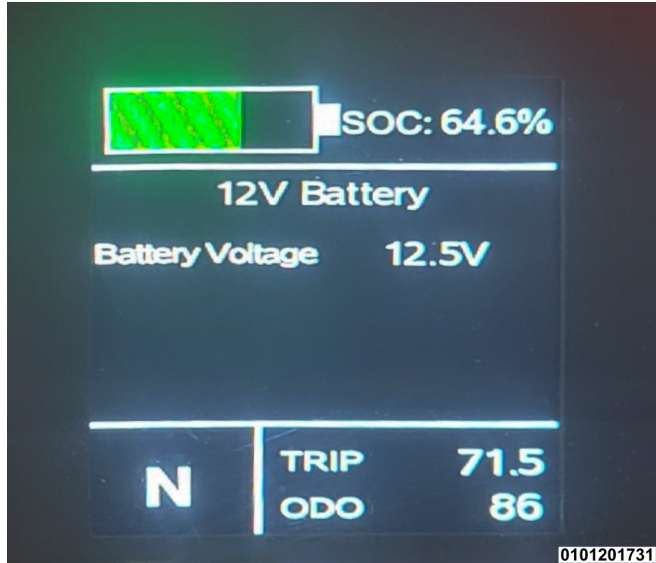

This messages provides information about the low voltage (12 volt) battery current voltage.

Trip Odometer

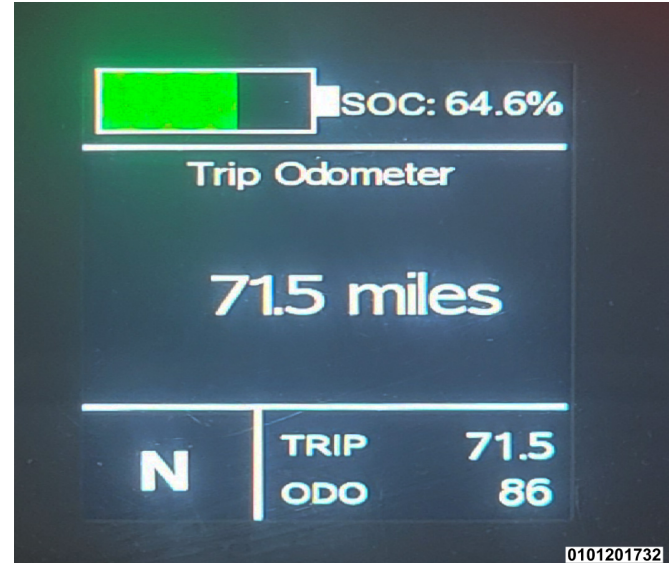

The trip odometer will measure the distance traveled on a trip. The driver can press and hold the TRIP button on the end of the multifunction lever to reset the trip odometer back to zero.

1
2
3
4
5
6
7
8
9
10
11

INSTRUMENTS AND CONTROLS

Backlight Setting

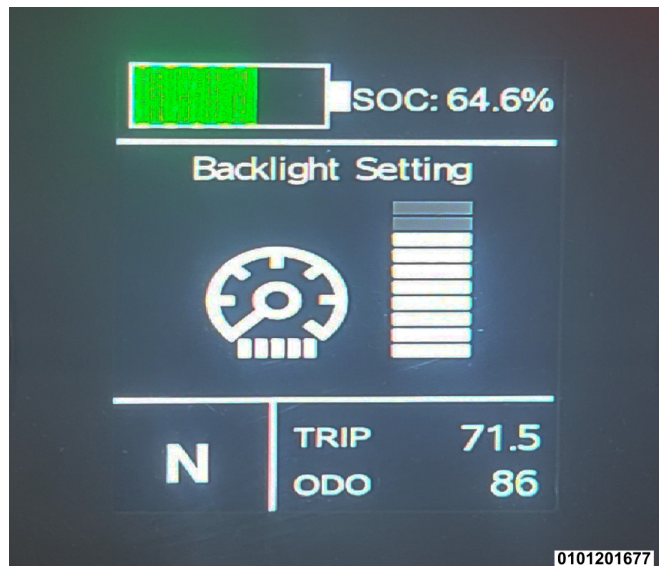

The backlight setting allows the driver to adjust the amount of illumination in the display screen. Press and hold the TRIP button to change lighting settings once at the Backlight screen. The backlight setting will work when the light switch is in the ON position.

English/Metric Setting

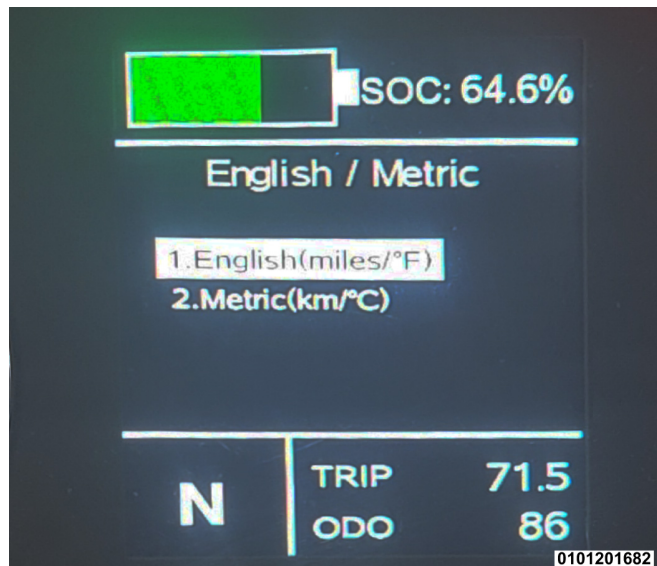

The English/Metric setting allows the driver to select the type of measurement standard displayed on the cluster, such as Miles/Kilometers or Fahrenheit/Celsius preferences. Once at the screen press and hold the TRIP button on the end of the multifunction lever, to switch between English/Metric choices.

EV Range

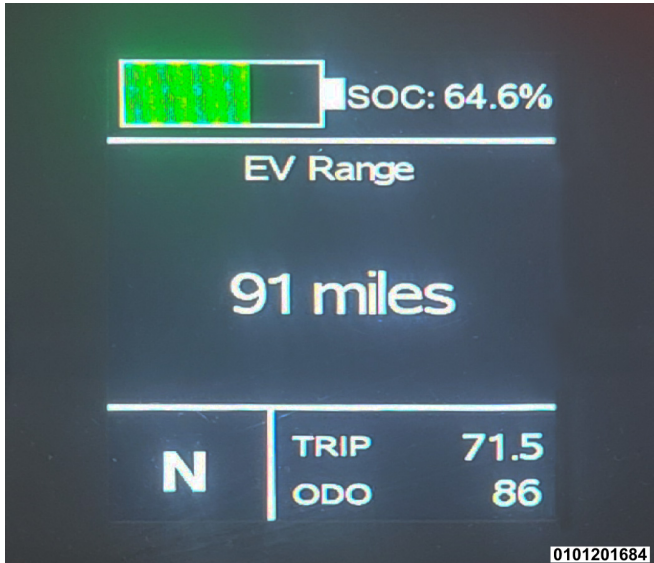

The EV Range screen tells approximately how many miles are remaining on a charge.

Clock Setting

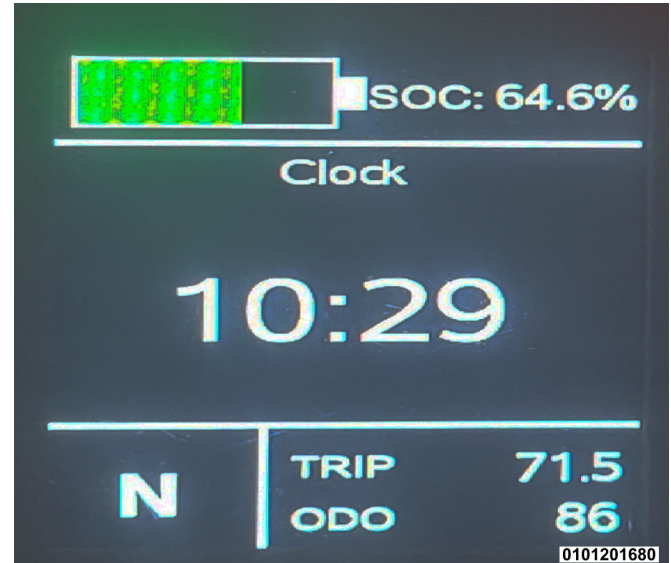

The clock screen displays the time and allows you to update the time from the TRIP button on the multifunction lever.

1
2
3
4
5
6
7
8
9
10
11

INSTRUMENTS AND CONTROLS

EV Batteries

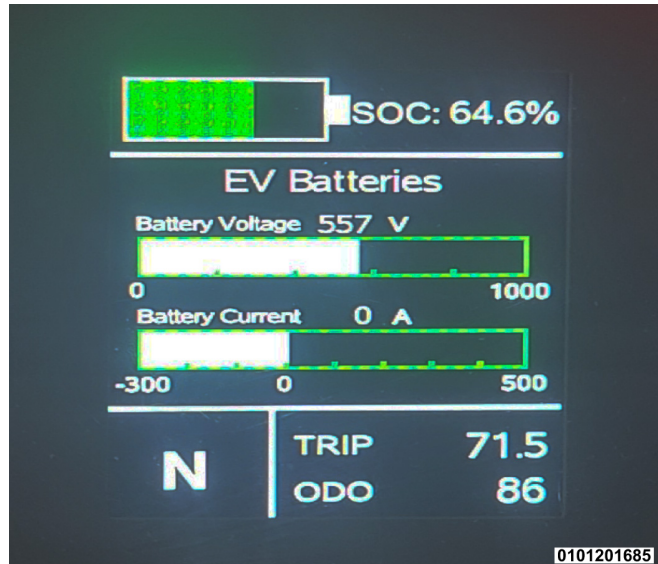

This screen displays the amount of Battery Voltage (V) or Battery Current (A) being used at a given time. Electrical consumption can be affected by various driving conditions, such as temperature, and weight of the vehicle load.

Door Open

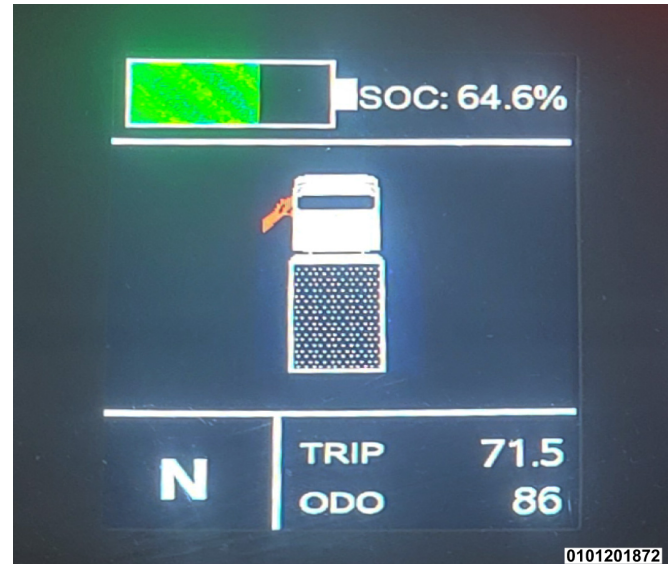

This screen display shows the status of the doors, open or closed or if either of the cab doors are not securely closed on the vehicle.

WARNING LIGHTS AND MESSAGES

Review this section to become more familiar with warning lights that may appear on your vehicles Instrument Cluster.

NOTE:

The indicators and warning lights can differ depending on vehicle configuration.

Anti-Lock Brake (ABS) Warning Light



This warning light monitors the ABS. The light will turn on when the ignition is placed in the ON position and may stay on for as long as 3 seconds. If the ABS light stays on for more than 3 seconds after multiple starts, please contact your authorized Mullen service center for inspection and repair.

NOTE:

For service, maintenance, or inquiries, refer to the [Customer Assistance p. 162](#) chapter for contact information.

Driving Power Limited Light

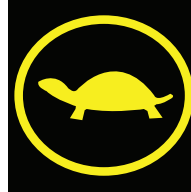

This light displays briefly during start up of the vehicle to check the system. If the yellow indicator comes on and stays on while driving, it indicates that the driving power is limited.

The driving power limit indicator will light if the vehicle has a secondary fault. The vehicle needs attention in this event, but it is drivable in what is sometimes called “limp-home mode” where the power is limited and the speed is reduced. Once you have limped home, or to a similar safe location, make arrangements for diagnostic service and vehicle repair at an authorized Mullen service center.

NOTE:

For service, maintenance, or inquiries, refer to the [Customer Assistance p. 162](#) chapter for contact information.

1

2

3

4

5

6

7

8

9

10

11

INSTRUMENTS AND CONTROLS

Electronic Power Steering Light



This light displays briefly during start up of the vehicle to check the system.

If the warning lamp is on in driving process, it stands for failed electric power steering system. See an authorized Mullen service center.

NOTE:

For service, maintenance, or inquiries, refer to the [Customer Assistance p. 162](#) chapter for contact information.

Low Charging Status Light

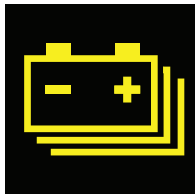

The Low Charge Status indicator light comes on briefly when the vehicle powers on during self-test. If the indicator light comes on and begins to flash, it means that the charge level of the high voltage battery is below 20% and the vehicle will run under limited power reducing acceleration and maximum speed. The vehicle will need to be charged as soon as possible.

Driving repeatedly with the State of Charge (SOC)

below 20% will result in decreased battery performance and life.

In addition to reduced overall vehicle speed, the air conditioning and heating functions will be disabled to conserve the electrical load on the batteries. Every effort should be made to coordinate the driver's route to

the nearest available re-charging station. Loss of the heating and cooling functions may result in reduced temperature comfort, or fogging of the windshield.

NOTE:

Use extra care when driving the vehicle in a low state of charge, especially on congested roads or highway speeds. Every effort must be made to drive the vehicle to a "safe" location to avoid collisions with other faster moving vehicles.

Rear Fog Lights

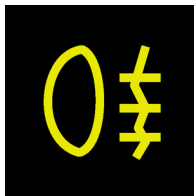

The rear fog lights indicator comes on briefly when the vehicle powers on during self-test (rear fog lights disabled).

Anti-Theft Light

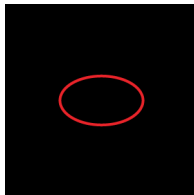

The vehicle anti-theft light will turn on when the vehicle is not locked successfully or a locked door is opened without using the key or key fob. The turn signal lights will continue to flash and the horn will sound repeatedly to give an alarm when either door is opened. When the system gives an alarm, press the unlock button on the key fob twice within 2 seconds to terminate the anti-theft alarm.

Brake System Indicator Light



This light will turn on when there is a fault in the braking system for the vehicle. If the light stays on while driving, contact an authorized Mullen service center.

NOTE:

For service, maintenance, or inquiries, refer to the [Customer Assistance p. 162](#) chapter for contact information.

High Voltage Battery Fault Light



Powers on as self-test during initial start of vehicle. If the light comes on and stays on while driving, there is a failed power storage battery. The battery system requires inspection and repair when the high voltage battery fault indicator displays. Please contact an authorized Mullen service center for assistance.

NOTE:

For service, maintenance, or inquiries, refer to the [Customer Assistance p. 162](#) chapter for contact information.

Charging Plug Connection Light



The charging indicator displays when the high voltage batteries are charging.

Drive Motor Fault Light



When illuminated, the drive motor is not operating properly. When safe to do so, stop the vehicle and turn the vehicle off. Seek service from an authorized Mullen service center.

NOTE:

For service, maintenance, or inquiries, refer to the [Customer Assistance p. 162](#) chapter for contact information.

1
2
3
4
5
6
7
8
9
10
11

INSTRUMENTS AND CONTROLS

Electronic Brake Distribution (EBD) - Light



This light displays briefly during start up of the vehicle to check the system.

When the red indicator light comes on and stays on during the driving process, it stands for failed EBD system. In such case, EBD system is shut down and the braking system can still work normally; however, it still needs to be detected as soon as possible. See an authorized Mullen service center for assistance.

NOTE:

For service, maintenance, or inquiries, refer to the [Customer Assistance p. 162](#) chapter for contact information.

Parking Brake Light



This indicator light will turn on briefly as part of the systems check when the vehicle is started and will stay on when the driver activates the parking brake. If the light stays on after the parking brake is released, contact an authorized Mullen service center.

NOTE:

For service, maintenance, or inquiries, refer to the [Customer Assistance p. 162](#) chapter for contact information.

Hazard Lights

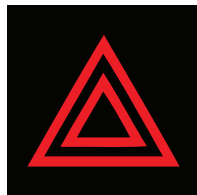

This indicator light will be on if the hazard warning light switch is turned on. The front, rear, left, and right turn signal lights will flash on and off to bring caution to other drivers.

Press the button again to turn off the hazard warning light and all turn signal lights will stop flashing.

Seat Belt Reminder Light



This indicator light will turn on when the driver's seat belt is not fastened and the vehicle is powered on. The seat belt warning light will stay on and a warning chime will sound until the driver's seat belt is fastened. The light will turn off when the driver's seat belt is buckled.

Vehicle Disable Indicator



The system fault indicator signals that the vehicle is experiencing a malfunction of the vehicle system and should be stopped as soon as it is safe to do so. Seek service from an authorized Mullen service center.

Front Fog Light

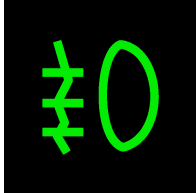

This light will turn on when the vehicle fog lights are turned on.

Parking/Headlights Indicator Light

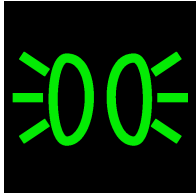

This indicator light will illuminate when the parking lights or headlights are turned on.

READY Light



When turning the vehicle on, the Ready light will illuminate in the instrument cluster. After completion of high voltage electrification and when the vehicle is ready to drive, the lamp will be on. This light will stay on while driving.

Turn Indicator Lights

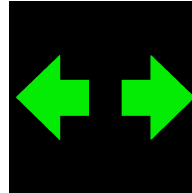

These lights indicate the working condition of the turn indicators. Normal flashing indicates the lights work properly. When they quickly flash, this indicates that one turn indicator light or both have a fault. It is recommended to take your vehicle to an authorized Mullen service center for inspection. Both of these lights will flash in the instrument cluster when the hazard lights are turned on.

High Beams Indicator



This indicator light will be on if the light combination switch is at the high beams position.

1

2

3

4

5

6

7

8

9

10

11

INSTRUMENTS AND CONTROLS

TOUCHSCREEN DISPLAY RADIO

Your vehicle is equipped with an interactive Touchscreen Display Radio located to the right of the steering wheel. This feature allows the driver to interact with user-adjustable controls, settings and functions.

This display will turn on with the vehicle. You can also turn it on or off by pressing the power button on the left side of the faceplate.

Radio Introduction

Radio Home Screen

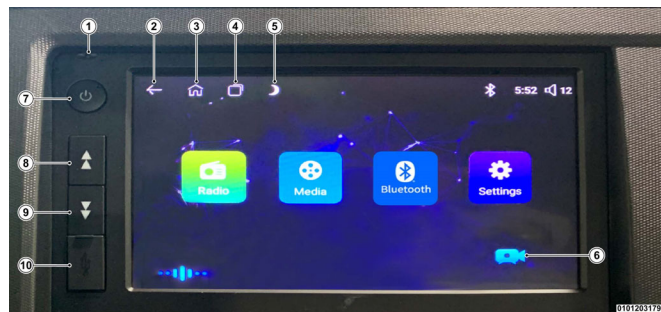

1. **Microphone** - This is the microphone for using the phone features.
2. **Back** - Touch the back arrow to go back to a previous screen on the radio.
3. **Home** - This will take you back to the main touchscreen.
4. **Screen options** - You can scroll through the most recent screens that were open.

5. **Night mode** - This touchscreen feature will allow you to make the screen darker or lighter.
6. **Backup camera (if equipped)** - Displays behind the vehicle on the radio screen.
7. **Power** - This will turn the radio on or off.
8. **Seek Up** - Move up the dial between radio stations or favorites.
9. **Seek Down** - Move down the dial between radio stations or favorites.
10. **USB Port** - USB port to charge or plug in your phone or other electronic devices.

Cleaning your Radio Touchscreen

From time to time, your radio touchscreen may get dirty. If the touchscreen becomes dirty, use a clean soft cloth to remove spots. If the panel is very dirty, wipe with a mild detergent, then use a clean soft cloth to wipe off the cleaner.

CAUTION!

Using a hard cloth or a volatile liquid (such as thinner) to wipe the touchscreen or panel of the radio may damage it.

General Information

The following regulatory statement applies to all radio frequency (RF) devices equipped in this vehicle.

This device complies with Part 15 of the FCC Rules and RSS standard(s).

The radio FCC ID: 2BB5BHMD-2176A-B.

Unintentional Radiators:

- FM Radio
- AM Radio

Operation is subject to the following two conditions:

1. This device may not cause harmful interference, and
2. This device must accept any interference received, including interference that may cause undesired operation.

NOTE:

Changes or modifications not expressly approved by the party responsible for compliance could void the user's authority to operate the equipment.

Bluetooth®

In the Bluetooth® icon on the home screen, you can control devices paired with the radio. These paired devices can be used to make phone calls and play music from your vehicles radio.

Follow the steps in this section to learn about how to pair and delete a phone or device from your vehicle.

Pairing a Phone/Bluetooth® Device

NOTE:

You must have Bluetooth® enabled on your device to complete this procedure. The vehicle should not be moving when pairing a device with the radio.



Pairing a phone or Bluetooth® device is simple and straight forward. Follow these steps:

1. Make sure the vehicle ignition is in ACC or ON.
2. On the touchscreen press "Settings" then select Bluetooth® to pair a phone.
3. Look in the Bluetooth® settings on your cellular device for the name of the vehicle (Mullen) and select to pair to the vehicle.

1

2

3

4

5

6

7

8

9

10

11

INSTRUMENTS AND CONTROLS

- Then on the radio screen, look for the name of your phone.
- A message will appear on your device for entering a PIN.

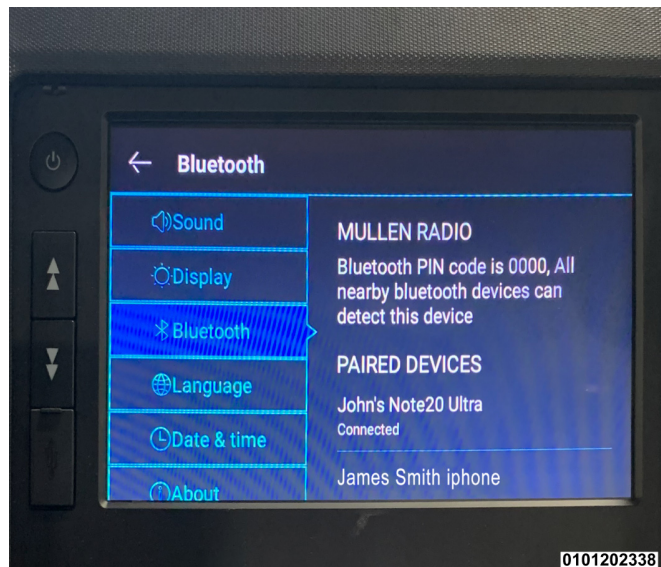

- Touch the screen on the name of the Paired Device.
- Once the vehicle is selected on your cell phone, the pairing process is completed.

NOTE:

After pairing your device with the radio, your phone will automatically connect to the radio upon turning the vehicle ON.

Unpairing A Phone



To unpair a phone from the Bluetooth® device, follow these steps:

1. On the Home screen, select “Settings”, then “Bluetooth®”.
2. When in the Bluetooth® screen, find the phone that is paired with the vehicle that you wish to disconnect. Touch and hold the phone or device name that you want to remove. A pop up will appear asking you to confirm that this is the phone you wish to Unpair.
3. Confirm this on the screen to delete the device.

Phone Mode

Follow the steps and instructions in this section to become more familiar with how your phone can interact with your vehicle.

Bluetooth® Screen

After successfully pairing your phone with the vehicle, options will appear for your phone interface with the vehicle. To access the phone features with your vehicles radio, select the Bluetooth® icon on the Main Menu. You can make calls using the Dialing keyboard, Linkman (downloaded contacts), or your recent call activity on the callLog screen.

Dialing Keyboard

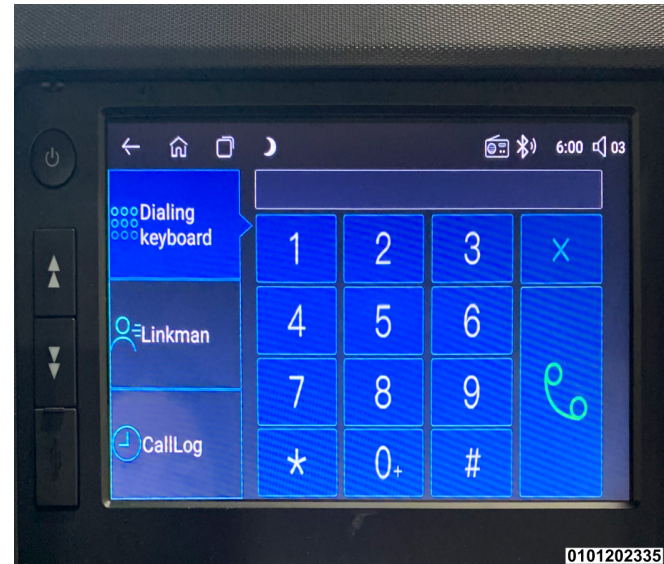

When a phone is connected with the vehicle you can make a call by entering a number in the touchscreen radio keyboard. To manually type in a phone number, use the Dialing keyboard. Enter the number and press the phone symbol to activate the call.

You can also end any current call by pressing the end call symbol.

1
2
3
4
5
6
7
8
9
10
11

INSTRUMENTS AND CONTROLS

Linkman Phonebook

You can access your phonebook contact list by selecting the Linkman function.

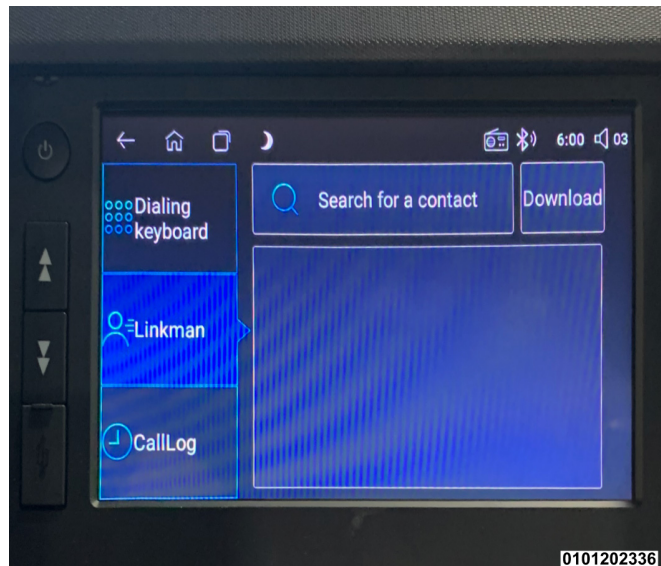

In the Linkman screen, you can download, search, or scroll the contact list from your paired device. Select the contact and make a call.

Recent Call History

The CallLog function on the phone will pull up the list of recent calls.

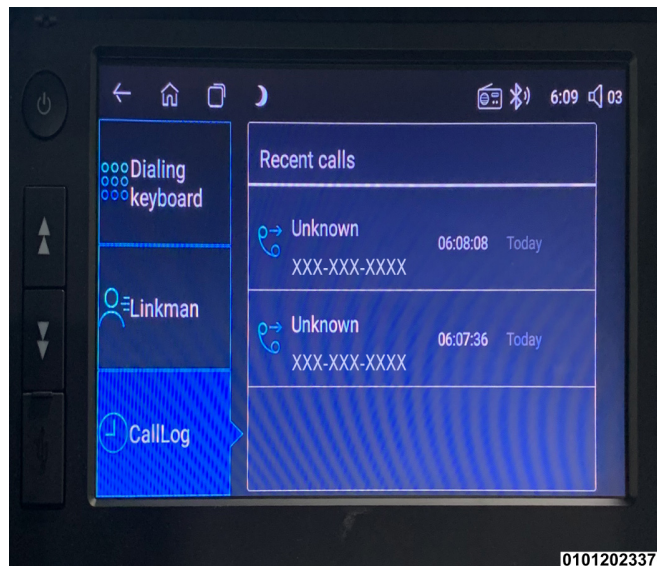

To call a contact you have recently dialed, touch the screen of the name/number listing.

Radio Mode

Follow steps and directions in this section to become more familiar with the radio functions on your vehicle.

Radio Operation

To access the radio on your vehicle, select the Radio button on the Home screen.



1. **Radio Station Favorites List** - Press the touchscreen to display a list of radio stations selected as favorites. You can scroll up or down the list by dragging up or down on the touchscreen. Tap on the radio station in the list you wish to listen to.
2. **Current Radio Station** - Displays the current radio station playing.
3. **Favorite** - Press to add the current radio station to the favorites list. Press the heart again to deselect a station from the favorites list.
4. **Frequency Source** - AM or FM
5. **Seek Up** - Press the touchscreen to seek radio stations up the radio dial.
6. **Pause/Play** - Press the touchscreen to pause a song playing on the radio or play list, press it again to begin playing again.
7. **Seek Down** - Press the touchscreen to seek down the lower numbers on the left of the radio dial.
8. **Search** - Press to search a radio station by manually entering a specific radio station number.

1
2
3
4
5
6
7
8
9
10
11

INSTRUMENTS AND CONTROLS

Media Mode

Music Operation

Your radio has the option to play music with your phone or Bluetooth® enabled device through BTMusic function on the touchscreen. Press the Media button on the Home screen and then Music to adjust preference options.



The Sound options on the touchscreen allow you to adjust equalizer sound, favorites, play lists, and the order the music is played.



1. **Equalizer** - Touch the screen to adjust the tone of the music low or high. You can also select the tone based on the type of music you are listening too. Flat, Popular, Rock, Classical or Jazz.
2. **Favorites List** - List of favorite radio stations, you can scroll up or down the list by touching the screen.

3. **List of songs** - Your music playlist from your mobile device, or phone.
4. **Song order** - Allows you to choose the order of the songs from your playlist.

Single loop Will repeat the same song.



Random mode will play the play list in a random order.



1
2
3
4
5
6
7
8
9
10
11

INSTRUMENTS AND CONTROLS

Sequence mode will play the play list in the order the songs occur.



List loop will play the play list in a repeated loop.



Bluetooth® Playlist Functions

On the Homescreen, select Media and then BTMusic.



You can download and connect your preferred songs and play lists using this function. You can also seek up or down or pause your playlist songs from the screen below.



1
2
3
4
5
6
7
8
9
10
11

INSTRUMENTS AND CONTROLS

Radio Settings

Radio Settings

To access your customizable settings, select the “Settings” function on the Home screen.

In the “Settings” function you will be able to adjust the Sound, and Display of the radio screen, Bluetooth® settings, Language preference, Date and Time settings on your radio.

Sound Settings

To access the sound settings for your radio, touch “Settings” on the Home screen and then select “Sound”. This will allow you to adjust Media volume, turn on or off Notifications, Keytone sounds on or off and adjust the equalizer settings.



Voice

Choose "Voice" settings to adjust the tone lower or higher. It can also adjust the tone to a certain music genre, such as User, Popular, Rock, Classical, or Jazz.



Scene

The "Scene" setting allows you to customize where the sound will come from on your vehicle. These sounds option can direct the sound more to the driver (left) or passenger (right) in the vehicle.



1
2
3
4
5
6
7
8
9
10
11

INSTRUMENTS AND CONTROLS

Display

Select the “Settings” function on the Home screen. In the Display function, you can adjust the brightness of the radio screen or change the screen background by choosing from various wallpapers.



Brightness Settings — Simply slide the bar left or right to make the radio display screen brighter or darker.



Wallpaper Settings — Scroll over the wallpaper background options and touch the screen to select the wallpaper you prefer. Then select the check on the touchscreen in the upper right corner to apply your selection.



Press the back arrow in the upper left corner of the display screen to return to the “Settings” screen.

Bluetooth® Settings

The Bluetooth® setting shows you the Bluetooth® PIN code, and lists any paired devices. You can also touch the screen on the name of the connected device to unpair.

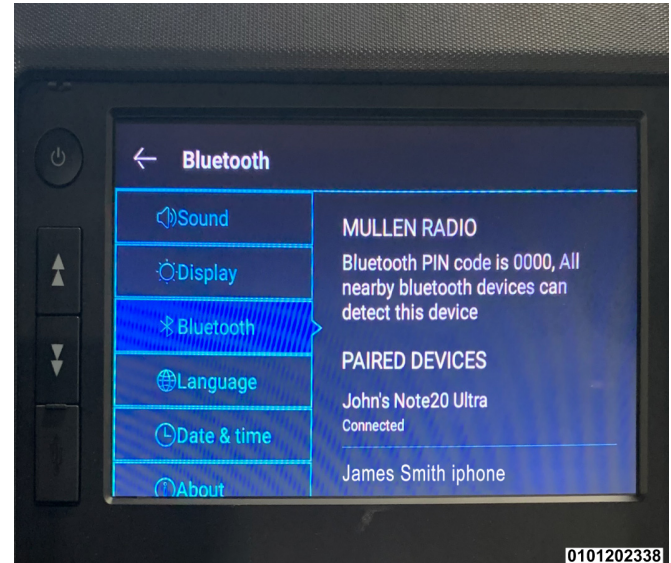

1
2
3
4
5
6
7
8
9
10
11

INSTRUMENTS AND CONTROLS

Language Setting

Currently the vehicle is set to English in the language display setting.



Location Setting

Selecting Location on the Personal Settings will give options related to GPS and other options related to location.

Accounts Setting

Selecting Accounts on the Personal Settings will give options related to setting up accounts and accounts linked to the radio.

Languages & Input Setting

Selecting Languages & Input on the Personal Settings will give options related Languages and Inputs for the radio.

Selecting Languages in the setting will give options for what language will display on the radio screen. Some examples are English, Spanish, and French.

The Input settings has multiple options for on screen keyboards regarding your radio. See available features:

- Virtual Keyboard
- Current Keyboard
- Google Keyboard

Selecting one of these options will open more detailed options for that selected feature.

Date & Time Settings



With the Date & Time settings you can adjust the following:

- Date
- Set the time
- Choose if you want to use a 24 hour format.

Simply touch the screen to adjust. Once you have made your selections, press the back arrow in the upper left corner of the screen to return to the settings screen.

TELEMATICS

Mullen is committed to helping fleets improve cost savings, safety, training, productivity and emissions impact. “Commercial Pulse” advanced telematics system for electric fleet optimization, provides managers and drivers with a connected fleet of vehicles with maintenance alerts, real-time vehicle location, driver safety, battery state of charge, metrics and more.

PULSE FLEET Manager App

If you are a fleet manager, you can download the PULSE FLEET Manager App from the “App Store” for iPhone or “Google Play” for Android. The Commercial Pulse Telematics System is designed to help improve safety, efficiency, and productivity. It gives you complete visibility of your fleet options, whether from behind a desk with the end user Dashboard capabilities or on a mobile device while you are on the go.

PULSE DRIVER App

If you are a driver of a fleet vehicle, the PULSE DRIVER App can be downloaded from the “App Store” for iPhone or “Google Play” for Android. The Driver Mobile App can provide information such as Routing Assistance, Real-Time Location, Charging Station Locator, or Roadside Assistance.

To learn more about the Commercial Pulse electric fleet optimization, or sign up for a subscription, please visit the website below:

<https://mullencommercial.com/pulsetelematics>

NOTE:

For service, or additional assistance, refer to the [Customer Assistance p. 162](#) chapter for contact information.

1

2

3

4

5

6

7

8

9

10

11

INSTRUMENTS AND CONTROLS

Telematics Getting Started

Before you get started you will need:

- The Vehicle Identification Number (VIN) of each vehicle you want to activate.
- Your main user's log-in and password; new customers will be asked to register.
- If you are a new customer, you will need company credit card information or invoice number as further proof of customer identification. Don't worry, you will not be charged.
- Go to <https://mullencommercial.com/pulsetelematics>. If you are an existing customer, enter your company's log-in credentials. New customers will need to register to create a new account.
- Manually enter the VIN(s) or upload a CSV file with your VIN(s). A vehicle name is optional and can be added later. Follow online instructions to complete your vehicle entry.
- Create a password and enter billing information. An email will be sent to you to complete the final step. After that, you will be ready to log-in and access the system
- You are good to go! You will receive an email confirming your vehicles are now online.

For more information, reach out to Mullen by referring to the [Customer Assistance p. 162](#) chapter for contact information.

Telematics General Information

Modification Statement

Mullen has not approved any changes or modifications to this device by the user. Any changes or modifications could void the user's authority to operate the equipment.

Interference Statement

This device complies with Part 15, 21, 22, 24, and 27 of the FCC and RSS standard(s). Operation is subject to the following two conditions: (1) This device may not cause interference, and (2) This device must accept any interference, including interference that may cause undesired operation of the device.

RF Exposure

This equipment complies with FCC and IC radiation exposure limits set forth for an uncontrolled environment. The antenna should be installed and operated with minimum distance of 20 cm between the radiator and your body.

FCC ID Information

The following regulatory statement applies to all radio frequency (RF) devices equipped in this vehicle.

This device complies with Part 21 of the FCC Rules and RSS standard(s).

Telematics FCC ID: 2A673-SRTL-TCU.

Unintentional Radiators:

- Telematics

Operation is subject to the following two conditions:

1. This device may not cause harmful interference, and
2. This device must accept any interference received, including interference that may cause undesired operation.

NOTE:

Changes or modifications not expressly approved by the party responsible for compliance could void the user's authority to operate the equipment.

CLIMATE CONTROLS

Climate Control Overview



- | | |
|---------------------------------------|---------------------------------|
| 1. A/C (Air Conditioner) power button | 3. Recirculation button |
| 2. Fan speed dial | 4. Air flow mode selection dial |
| | 5. Heat button |

NOTE:

To use the heat button, the A/C button will have to be turned off.

The Climate Control system allows you to heat, cool, and direct the flow of air circulation throughout the vehicle. The Climate Controls are located under the radio controls. Here are some helpful user tips:

- To defrost the windows, push the heat button in the electrical switches below the climate control dials and turn the mode dial to defrost.
- If the A/C button is on and the heat button is turned on at the same time, the A/C button will over ride the heat selection.
- The A/C button must be turned off to use the heat button.
- A/C or Heat buttons will only work when the fan speed dial is first turned to 1-4.

Adjustable Vents

You can direct or limit the amount of air flow by using the thumb wheels on the vents across the instrument panel. You can direct the air flow up, down, left or right, or reduced flow to a specific vent.

Fan Speed Dial

To adjust the fan blower speed, turn the center dial from 0 to 4. To turn the fan speed off set the dial to 0, to add airflow, set the dial between 1 and 4. Airflow will come from the vents depending on the MODE dial selection.

NOTE:

- The higher the fan speed is, the more of a drain it will be on your vehicles high voltage batteries.
- A/C or Heat will turn on when the fan dial is set to speed 1 to 4.

1

2

3

4

5

6

7

8

9

10

11

INSTRUMENTS AND CONTROLS

Mode Control Dial

The right dial can be used to change the direction of the airflow distribution. The airflow can be changed by rotating the mode dial to the instrument panel vents, floor outlets, or windshield defrost outlets. The instrument panel vents can be directed by using the thumb wheel to move the air flow direction and also to close individual vents.

Instrument Panel Mode



In this mode, airflow will come out of the vents along the instrument panel.

Bi-Level Mode



In this mode, airflow will come from the vents along the instrument panel and also the floor. This mode offers the most airflow for the driver and passengers.

Floor Mode



In this mode, air comes from the floor outlets. In this mode some air is directed through the defrost and side window demister outlets.

Mix Mode



In this mode, air flow is directed through the defrost, side window, and floor vents. This mode is ideal to provide airflow to you and to the windshield.

Defrost Mode



This mode will defrost the front windshield. To defrost the windshield, turn the mode dial to the defrost setting and turn the fan speed on 4 (high). Then push the heat button, with the same symbol in the instrument panel switches, directly below the climate control dials.

A/C (Air Conditioner) Button

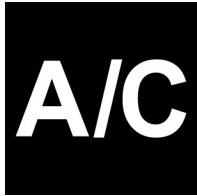

Press the A/C (Air Conditioner) button to turn on the air conditioner to cool the vehicle cab. The A/C can be turned on and controlled by using the center fan blower speed dial positions 1-4.

For maximum cooling, turn the fan speed dial on 4, and the MODE dial to the instrument panel vent outlets. The recirculation button (located between the fan speed and the MODE selection dials) can be used with the A/C and will circulate

the cooling air within the cab.

NOTE:

If driving the vehicle in a State of Charge below 20%, loss of the heating and cooling functions may result in reduced temperature comfort, or fogging of the windshield. Make sure the vehicle is fully charged for optimum functionality.

Recirculation Button



Pressing the button between the fan speed and mode dial will turn on air recirculation. Recirculation closes the vent intake of outside air and recirculates air within the cab. It can be used when outside conditions such as smoke, odors, dust, or high humidity are present. Recirculation can be used in all modes and can accelerate air cooling within the cab.

Recirculation may be unavailable if conditions exist that could create fogging on the inside of the windshield. The A/C can be deselected

manually without disturbing the mode control selection. Continuous use of the recirculation mode may make the inside air stuffy and window fogging may occur. Extended use of this mode is not recommended. Recirculation mode may automatically adjust to optimize customer experience for warming, cooling, dehumidification, etc.

NOTE:

In rainy or cold weather, it is not recommended to use the recirculation button as it may lead to excessive window fogging. The recirculation feature may be unavailable if conditions exist that could create fogging on the inside of the windshield.

Heat Button



The heat button is located in the electrical switches below the climate control. This button will create heat in the vehicle when the A/C button is not in use.

The heat button can only be used when the A/C button is off and the fan speed dial is turned to speeds 1-4, it will also defrost the front windshield when the defrost mode is selected on the Mode dial.

NOTE:

If driving the vehicle in a State of Charge below 20%, loss of the heating and cooling functions may result in reduced temperature comfort, or fogging of the windshield. Make sure the vehicle is fully charged for optimum functionality.

1

2

3

4

5

6

7

8

9

10

11

SAFETY FEATURES	80
Anti-Lock Brake System (ABS)	80
Anti-lock Brake System Precautions	80
OCCUPANT RESTRAINT SYSTEMS	81
Seat Belts	81
Fastening The Seat Belt	82
Disengaging The Seat Belt	82
SAFETY TIPS	83
Safety Checks Inside The Vehicle	83
Periodic Safety Checks Outside The Vehicle	84

1

2

3

4

5

6

7

8

9

10

11

SAFETY FEATURES

Anti-Lock Brake System (ABS)



The Anti-Lock Brake System (ABS) provides increased vehicle stability and brake performance under most braking conditions. The system automatically prevents wheel lock and enhances vehicle control during braking.

The ABS is activated during braking when the system detects one or more wheels are beginning to lock. Road conditions such as ice, snow, gravel, bumps, railroad tracks, loose debris, or

panic stops may increase the likelihood of ABS activation.

In situations when the user presses the brake pedal with excessive force or speed, the Anti-Lock Brake System will automatically activate.

- The vehicle will use the Anti-Lock Brake System to decelerate the vehicle while maintaining stability.
- The rear brake lights will illuminate.

WARNING!

- The ABS contains sophisticated electronic equipment that may be susceptible to interference caused by improperly installed or high output radio transmitting equipment. This interference can cause possible loss of anti-lock braking capability. Installation of such equipment should be performed by qualified professionals.

WARNING! (Continued)

- Pumping of the Anti-Lock Brakes will diminish their effectiveness and may lead to a collision. Pumping makes the stopping distance longer. Just press firmly on your brake pedal when you need to slow down or stop.
- The ABS cannot prevent the natural laws of physics from acting on the vehicle, nor can it increase braking or steering efficiency beyond that afforded by the condition of the vehicle brakes and tires or the traction afforded.
- The ABS cannot prevent collisions including those resulting from excessive speed in turns, following another vehicle too closely or hydroplaning.
- The capabilities of an ABS equipped vehicle must never be exploited in a reckless or dangerous manner that could jeopardize the user's safety or the safety of others.

Anti-lock Brake System Precautions

Anti-lock Brake System (ABS) is an active safety system, which can improve the operational safety of the vehicle. Compared with ordinary braking systems, ABS prevents the vehicle wheels from locking up during emergency braking, even on a smooth road surface. This ensures the steering control and vehicle stability perform to their maximum capability.

- ABS function is limited by the wheel road adhesive force. When driving a vehicle on a wet or smooth road surface and wheel locking is detected, be sure to reduce the speed to adapt for the road conditions and traffic status. Never risk the limited safety measures supplied by ABS.

- If ABS fails, the anti-lock system warning light will be on, but it will not effect the whole braking system. A vehicle with ABS errors needs to be repaired as soon as possible.

⚠ NOTE:

For service, maintenance, or inquiries, refer to the [Customer Assistance p. 162](#) chapter for contact information.

- Do not rely on ABS to reduce the braking distance in all cases. On certain occasions, such as on gravel roads or snow-covered road surface (the driver will need to adjust the speed of the vehicle), the braking distance may be longer.

OCCUPANT RESTRAINT SYSTEMS

Seat Belts

Your vehicles seat belts are a safety device which can prevent and relieve injury for the occupants when the vehicle is involved in emergency braking or a collision.

Make sure the seat is in an ideal position. Sit up straight and have your back against the seat.

⚠ WARNING!

- Do not place the seat belt over a hard or fragile object such as glass.
- The seat belt cannot be blocked, twisted or against a sharp object. It needs to be pressed as low as possible on the hips, not on the waist.
- Only one seat belt can be used for one person (even for a child).
- The opening on the seat belt receiver must be free of objects or debris; otherwise, the latch plate may not lock.
- Avoid seat positions that can hinder the correct placement for the seat belt.
- No alterations are allowed to the seat belts. Seat belts which are damaged or involved in an accident must be replaced.
- Keep the seat belt clean and dry.

1

2

3

4

5

6

7

8

9

10

11

SAFETY

For Pregnant Women

The seat belt needs to be worn securely and as low as possible over the hips, not the waist.

For Children

Mullen builds vehicles custom designed for commercial use only. We strongly advise against allowing children under 12 to ride in any position of the vehicle.

Children and adults less than 4.9 feet need to use a seat belt and booster seat specifically for their size.

WARNING!

- Wearing a seat belt incorrectly may cause serious personnel injuries or death. In case of emergencies, unprotected passengers may collide with any part of the vehicle, including other passengers, or be thrown out of the vehicle and causing injuries or death.
- In case of torn, broken or worn seat belt, have it replaced.

Fastening The Seat Belt

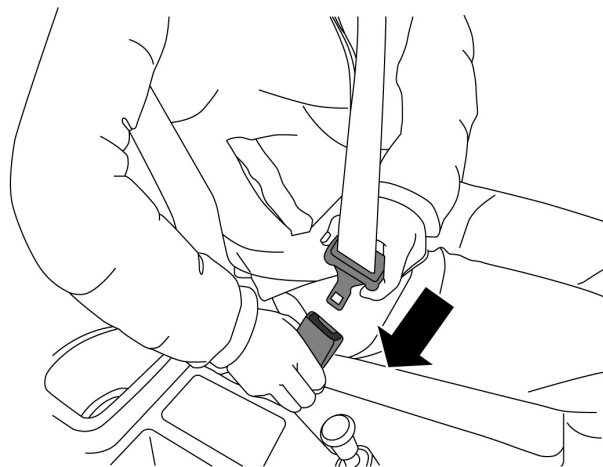

0101201389

Locking the Seat Belt

- Insert the latch plate into the buckle until an engagement sound is heard.
- Pull the seat belt on both ends to check whether it is buckled.

Disengaging The Seat Belt

Press down the red button on the seat belt buckle and the latch plate will release under the force of the spring. The seat belt can then be disconnected.

SAFETY TIPS

Transporting Passengers

NEVER TRANSPORT PASSENGERS IN THE CARGO AREA.

NOTE:

Mullen builds vehicles custom designed for commercial use. We strongly advise against allowing children under 12 to ride in any position of the vehicle.

WARNING!

- Do not leave children or animals inside parked vehicles in hot weather. Interior heat build-up may cause serious injury or death.
- It is extremely dangerous to ride in a cargo area, inside or outside of a vehicle. In a collision, people riding in these areas are more likely to be seriously injured or killed.
- Do not allow people to ride in any area of your vehicle that is not equipped with seats and seat belts.
- Be sure everyone in your vehicle is in a seat and using a seat belt properly.

Safety Checks Inside The Vehicle

Seat Belts

Inspect the seat belt system periodically for cuts, frays, and loose parts. Damaged parts must be replaced immediately. Do not disassemble or modify the system.

Defroster

Check by selecting the defrost mode and place the blower control speed on high, then press the heat button on the instrument panel. You should be able to feel the air directed against the windshield. See an authorized Mullen service center if your defroster is inoperable.

NOTE:

For service, maintenance, or inquiries, refer to the [Customer Assistance p. 162](#) chapter for contact information.

Floor Mat Safety Information

Do not use floor mats in this vehicle.

WARNING!

A damaged, folded, or stacked floor mat may cause your floor mat to interfere with the accelerator, or brake pedals. Objects can become trapped under the accelerator or brake pedals and cause a loss of vehicle control resulting in accidents or death. ALWAYS make sure objects cannot fall or slide into the driver's side floor area when the vehicle is moving.

1

2

3

4

5

6

7

8

9

10

11

SAFETY

Periodic Safety Checks Outside The Vehicle

Tires

Regularly inspect the vehicle wheels and tires for the following:

- Examine tires for excessive tread wear and uneven wear patterns.
- Check for stones, nails, glass or other objects lodged in the treads or sidewalls. Inspect the treads for cuts and cracks.
- Inspect sidewalls for cuts, cracks, and bulges.
- Check the wheel lug nuts for tightness. See “[Wheel And Tire Torque Specifications p. 155](#)”.
- Check the tires for proper cold inflation pressure. See “[Tire Inflation Pressure p. 135](#)” for further information.

Lights

Have someone observe the operation of brake lights and exterior lights while you work the controls. Check that the turn signals and high beams are in proper working order.

Door Latches

Check for proper closing, latching, and locking.

If any of the items have issues or problems, take your vehicle to an authorized Mullen service center.



NOTE:

For service, maintenance, or inquiries, refer to the [Customer Assistance p. 162](#) chapter for contact information.

NEW VEHICLE BREAK-IN MAINTENANCE	86
STARTING THE VEHICLE	86
Start Up Troubleshooting	87
Shutting Down The Vehicle	88
IMPROVING VEHICLE DRIVING RANGE	89
ACCELERATOR AND BRAKE PEDALS	89
Acceleration	90
Braking And Parking	90
REGENERATIVE BRAKING SYSTEM	91
PARKING BRAKE LEVER	91
GEAR SHIFT SELECTOR	93
BACKUP CAMERA (IF EQUIPPED)	94
Parking Sensor — If Equipped	94
VEHICLE LOADING DESCRIPTIONS	96
Certification Label	96
Gross Vehicle Weight Rating (GVWR)	96
Payload	96
Gross Axle Weight Rating (GAWR)	96
Tire Size	96
Rim Size	96
Inflation Pressure	96
Curb Weight	96
Loading	96

DRIVING TIPS	97
Proper Use Of Vehicle	97
Attentive Driving	98
On-Road Driving Tips	98
Driving Through Slippery Surfaces	98
Driving Through Water	99

1
2
3
4
5
6
7
8
9
10
11

STARTING AND OPERATING

NEW VEHICLE BREAK-IN MAINTENANCE

In order to maintain and prolong the service life of your vehicle, Mullen recommends new vehicle break-in maintenance starts from the day the vehicle is delivered to the user and the initial mileage of the vehicle is within the first 500 miles (804 kilometers). See “Maintenance and Service”, “[Daily Maintenance p. 123](#)” and “[Maintenance Intervals p. 124](#)” for regularly scheduled maintenance.

⚠ WARNING!

Overload Warning

The total weight of the vehicle must stay within the maximum allowable range. Try to evenly distribute the carrying payload. Overloading the vehicle will not only shorten the vehicle’s service life, but could also cause serious mechanical breakdowns and even accidents!

- The owner’s manual aims to provide users with detailed information for the best use of the vehicle and safety restrictions between the company and vehicle operators. Users shall carefully read the owner’s manual before using the vehicle. Any inappropriate application, maintenance or negligence and unauthorized refit may cause vehicle damages. This will not be covered by the warranty.
- Please contact Mullen customer support for service information.
- If the vehicle is damaged by natural disasters or human factors, these items will not be covered by the warranty.

⚠ NOTE:

For service, maintenance, or inquiries, refer to the [Customer Assistance p. 162](#) chapter for contact information.

STARTING THE VEHICLE

Follow these steps to start and drive your vehicle:

1. Turn the Master Power Switch to the ON position. The master power switch is located behind the cab on the driver side and above the black, exterior fuse box. The master power switch is ON when straight up and down and OFF when turned horizontally as shown.

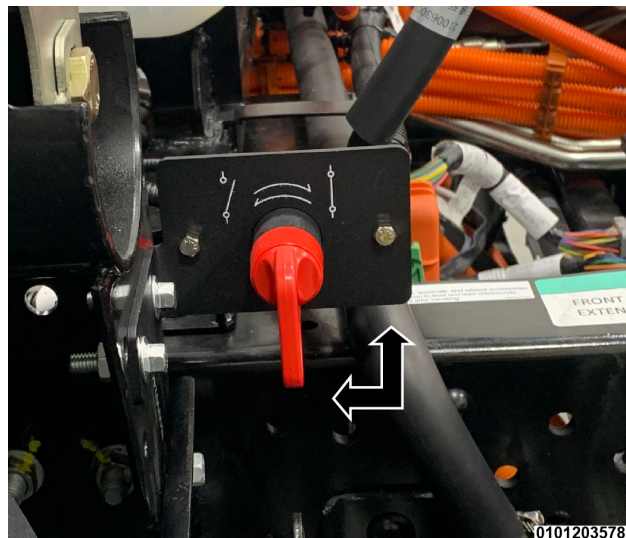

Master Switch (shown in ON position)

2. Fasten the seat belt.
3. Make sure the doors are all fully closed on the vehicle.
4. Before driving the vehicle, with your foot on the brake, make sure the gear shift lever is in NEUTRAL (N) position or the drive motor cannot be started.
5. Insert the key to engage the high voltage drive motor and steering mechanism.
6. While keeping your foot on the brake, turn the ignition key to the START position. The battery voltage will be displayed as high voltage, which means that the high voltage battery is working normally. Wait for the instrument cluster warning lights and indicators to come on and turn off. The drive motor will be started successfully when the green READY light is on.
7. Release the parking brake.

 **NOTE:**

- In case of invalid start, make sure the READY light is on in the instrument cluster.
- Do not step on the accelerator pedal forcefully while starting the vehicle. After starting the vehicle, immediately check the instrument cluster display and make sure indicators are operating normally.

Operation

After the drive motor is started, the green READY light on the instrument cluster display is turned on. The gear shift lever can be shifted to the DRIVE (D) or REVERSE (R) gear. Remove your foot from the brake and gradually press the accelerator pedal for operation.

 **WARNING!**

When driving the vehicle, never rotate the key to the STOP position or remove the key from starting switch! Doing so will cause the steering wheel to lock up and lead to traffic accidents.

 **NOTE:**

For any maintenance or repairs, refer to the [Customer Assistance p. 162](#) chapter for contact information or service to high voltage systems, cables or drive motor.

Start Up Troubleshooting

If the vehicle does not start after following the normal starting procedure, follow these steps:

1. Apply the parking brake and shift the gear shifter into NEUTRAL (N).
2. Turn the vehicle ignition to the OFF position and wait for 30 seconds.
3. Turn OFF the Master Switch (driver's side, behind the cab) and wait for 30 seconds. The vehicle will fully shut down.
4. Turn the Master Switch back to the ON position and retry following the steps for normally starting your vehicle.
5. If there is still an issue, look for any flashing or solid warning lights. Check for any error codes being displayed in the instrument cluster. If any are found, refer to the [Customer Assistance p. 162](#) chapter for service contact information.

1

2

3

4

5

6

7

8

9

10

11

STARTING AND OPERATING

When the vehicle is driven and charged on a regular basis, the auxiliary and low voltage battery will stay charged. If a vehicle is unused for an extended period of time, the auxiliary battery may lose its charge, and the vehicle may fail to start. To minimize the drain on the battery when the vehicle is parked and unused, make sure the doors are fully closed and locked and all accessories are turned OFF. Also, make sure the Master Switch is turned OFF.

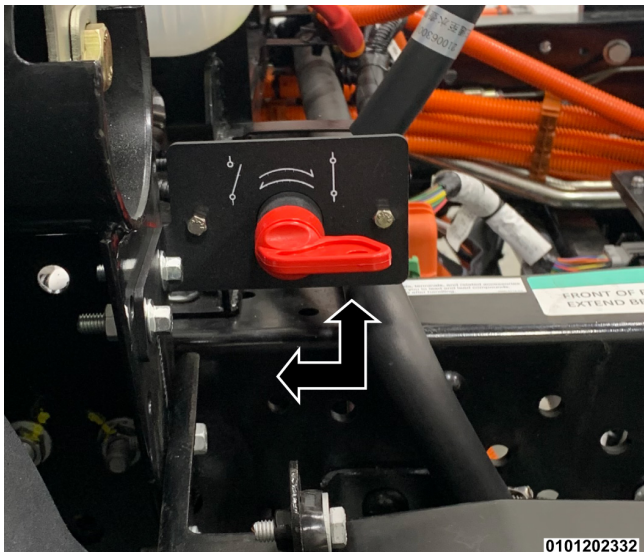

Master Switch (shown in the OFF position)

If the READY indicator does not display in the instrument cluster when the ignition key is turned to START, some possible causes could be:

- The high voltage battery is discharged. The vehicle will need to be charged.
- The low voltage battery may need to be fully charged before being used.
- Make sure the vehicle is in NEUTRAL (N). Turn the key to LOCK and shift the gear selector to NEUTRAL (N). Press the brake and turn the key to ON.

If your vehicle still does not start, do not attempt to dismantle the high voltage drive motor system. Inspection and maintenance must be performed by professional technicians only. Refer to the [Customer Assistance p. 162](#) chapter for service contact information.

Shutting Down The Vehicle

To fully shut down your vehicle, follow these steps:

1. Shift the gear selector in the NEUTRAL (N) position and set the parking brake.
2. Turn the key to the OFF position and remove it from the ignition.
3. Turn OFF the Master Switch located on the driver's side, behind the cab.
4. When the Master Switch is in the OFF position, the high voltage system is fully turned off. Make sure to not leave the keys in the vehicle.

NOTE:

If the high voltage batteries need charging, the Master Switch must be left ON.

IMPROVING VEHICLE DRIVING RANGE

The drive system and climate control system use the most energy from the high voltage batteries. Reducing energy draw from these features are the easiest and most effective way to extend driving range.

This vehicle uses high voltage components to heat and cool the cabin, shutting off the A/C or heat when not needed will help reduce the energy draw.

Colder external temperatures cause a decrease in the battery capacity and a corresponding decrease in the cruising range of the vehicle. This is normal and should be expected.

Additional tips to help extend the vehicle driving range:

- Keep tires properly inflated.
- When practical, choose surface streets over the highway, and work to maintain a steady speed.
- Avoid carrying nonessential cargo.
- Be mindful of adding external accessories that may increase aerodynamic drag.
- Perform all scheduled maintenance at recommended intervals.

NOTE:

The vehicle has a calibration that will reduce the power level if driven at maximum speed for more than 30 minutes. This reduced power level will result in a reduction of the top speed and lower the throttle response of the vehicle. Depending on the grade of the roadway the vehicle might not be able to maintain steady speeds when the power is reduced. Maximum power can be restored by pulling over in a safe location and cycling the ignition OFF then back ON.

ACCELERATOR AND BRAKE PEDALS

The acceleration, deceleration, and stopping of the vehicle is controlled by the accelerator and brake pedals. These pedals are located near the floor in front of the driver's seat. The pedal on the left is the brake and the pedal on the right is the accelerator.



1

2

3

4

5

6

7

8

9

10

11

STARTING AND OPERATING

Acceleration

Operation

When the ignition is turned ON, the READY light will turn on in the instrument cluster display. Shift the gear selector to DRIVE (D) or REVERSE (R), and gradually press on the accelerator pedal for operation.

WARNING!

When driving the vehicle, never rotate the key to the STOP position or remove the key from starting switch! Doing so will cause the steering wheel to lock up and lead to traffic accidents.

Braking And Parking

Brake Pedal

To decelerate the vehicle, press the brake pedal. When the brakes are applied, the rear brake lights will illuminate.

Vehicles equipped with an Anti-Lock Brake System (ABS), have the same braking characteristics as other vehicles. However, in case of emergency braking, the brake pedal needs to be pressed to the floor and held until the vehicle comes to a stop. Turn the steering wheel during the braking process to avoid obstacles. If braking on slippery roads, apply the brake using conventional methods

The vehicle is equipped with an auxiliary braking system (drive motor braking). The braking system is also equipped with energy recovery system. During normal braking, press the brake pedal steadily and smoothly to save vehicle energy.

NOTE:

- Under normal braking circumstances, ABS will not work until it detects that the wheels are about to be locked. When ABS is activated, the driver will feel a vibration in the brake pedal and hear some noises. This is normal.
- Do not pump the brakes on a vehicle equipped with ABS. Pumping the brakes will increase braking distance. Press firmly on the brake pedal when you need to slow down or stop. The system automatically prevents wheel lock and enhances vehicle control during braking.

Parking

1. Release the accelerator pedal and gradually step on the brake pedal.
2. After the vehicle is fully stopped, firmly pull up on the parking brake handle grip and shift into NEUTRAL (N) gear. See "[Parking Brake Lever p. 91](#)" for more information.

CAUTION!

- You must come to a complete stop between shifting gears from forward DRIVE (D) gear to REVERSE (R) gear and from REVERSE (R) gear to forward DRIVE (D) gear in the driving process.
- Gear shift lever must be in NEUTRAL (N) position when parking and before starting up the drive motor.
- Apply the parking brake lever even for temporary parking.
- Do not leave the vehicle before firmly applying the parking brake lever.

REGENERATIVE BRAKING SYSTEM

This vehicle has a regenerative (REGEN) braking system which is an energy recovery mechanism. The electric drive motor which propels the vehicle can operate as a generator when braking. The regenerative braking system recharges the high voltage batteries under certain braking conditions by recapturing energy that would otherwise be lost while braking. The electric power that is generated goes back into the high voltage batteries for later use, for example when acceleration is desired.

This feature is enabled and disabled depending on the high voltage batteries State of Charge (SOC) and vehicle speed. The regenerative braking system is activated when the SOC is between 95% and 8%. This feature ensures maximum battery life and vehicle performance generated from the high voltage batteries.

NOTE:

- The regenerative braking system is not active when the SOC is at a high percentage (100% to 95%).
- The rate of vehicle deceleration depends upon the overall weight of the vehicle, and it should be noted that the regenerative braking is deactivated as the vehicle slows down to 10 mph or less. Regenerative braking is not active at speeds under 10 mph.

CAUTION!

- Driver care and attention is needed when driving an incomplete (chassis-only) vehicle because the lower vehicle curb weight results in the REGEN calibration becoming more responsive. This creates abrupt acceleration and deceleration during activation.
- Please note that REGEN does not activate the vehicle's rear brake lights.

PARKING BRAKE LEVER



To engage the parking brake, pull up firmly on the parking brake lever. To release the parking brake, push the button on the end of the parking brake lever, lift up slightly and lower fully to disengage.

1

2

3

4

5

6

7

8

9

10

11

STARTING AND OPERATING

CAUTION!

The vehicle is not equipped with a park position in the gear selector. The parking brake must be engaged when your vehicle is in NEUTRAL (N) to prevent the vehicle from rolling while parked. Before leaving the vehicle, make sure the parking brake is applied securely with the gear selector in NEUTRAL (N).

WARNING!

- Never use the NEUTRAL (N) position as a substitute for the parking brake. Always apply the parking brake fully when parked to guard against vehicle movement and possible injury or damage. When exiting the vehicle, always turn the ignition OFF, secure the key fob, and lock your vehicle.
- Never leave children alone in a vehicle, or with access to an unlocked vehicle. Allowing children to be in a vehicle unattended is dangerous for a number of reasons. A child or others could be seriously or fatally injured.
- Do not leave the key fob in or near the vehicle, or in a location accessible to children. A child could operate power windows, other controls, or move the vehicle.
- Be sure the parking brake is fully disengaged before driving; failure to do so can lead to brake failure and a collision.
- Always fully apply the parking brake lever when leaving your vehicle, or it may roll and cause damage or injury.

Only use the parking brake while the vehicle is moving for emergency purposes. Never use the parking brake as a normal brake while driving.

CAUTION!

If a Brake System Warning Light remains on with the parking brake released, a brake system malfunction is indicated. Have the brake system serviced by a Mullen authorized service provider immediately.

NOTE:

For service, maintenance, or inquiries, refer to the [Customer Assistance p. 162](#) chapter for contact information.

GEAR SHIFT SELECTOR



The gear shift selector is used to shift between the driving gears DRIVE (D), NEUTRAL (N), or REVERSE (R). The vehicle must be in the NEUTRAL (N) position before you can start the vehicle. Apply the brakes before shifting into any driving gear.

Drive

Use DRIVE (D) for all normal forward driving. Make sure the brake pedal is pressed when shifting to the DRIVE (D) gear.

1. While the brake is being pressed move the shifter to the DRIVE (D) gear.
2. When the gear shift is engaged in DRIVE (D), gradually press the accelerator pedal to accelerate the vehicle forward.

Neutral

When the gear shift is in the NEUTRAL (N) position, and the parking brake lever is applied, the ignition key can be turned to OFF and removed. This will turn off the high voltage systems to the drive motor and lock the steering.

1. To shift out of NEUTRAL (N), make sure the brake pedal is pressed, then release the parking brake before shifting to another gear.
2. If the vehicle is parked while in NEUTRAL (N), the parking brake must be applied to prevent the vehicle from accidentally rolling.

⚠ WARNING!

- If the vehicle is parked while in NEUTRAL (N), the parking brake must be applied securely to prevent the vehicle from accidentally rolling, causing damage or injury.
- When changing gears, ALWAYS verify that the selected gear is displayed on the instrument panel. Improper shifting could cause the vehicle to move in an unexpected direction.

Reverse

Use REVERSE (R) to move the vehicle backwards. Shift into REVERSE (R) only after the vehicle is at a complete stop.

1. When the gear shift is engaged in REVERSE (R), gradually press the accelerator pedal to accelerate the vehicle backwards.
2. If equipped, the vehicles backup camera and parking sensor will turn on when the vehicle is in the REVERSE (R) gear.

1

2

3

4

5

6

7

8

9

10

11

STARTING AND OPERATING

BACKUP CAMERA (IF EQUIPPED)



A backup camera may be installed on the rear of the vehicle. The camera will automatically turn on whenever the vehicle is shifted into REVERSE (R). The camera will display the view behind the vehicle on your radio screen. The camera display will turn off when the vehicle is shifted out of REVERSE (R).

Parking Sensor — If Equipped

The parking sensor can detect obstacles at the back of the vehicle when installed. When the sensor detects an object it will make a sound through the instrument cluster to alert the driver of the approximate distance between the vehicle and object. The parking sensor will be operational when the key is rotated to the ON position and the gear shift lever is in REVERSE (R).

The closer the object, the more frequent the warning sound will be.

- If the object is greater than 5 ft. (1.8 m), the instrument cluster display will be silent.
- If the object is greater than 2 ft. (0.8 m), but less than or equal to 5 ft. (1.8 m), the instrument cluster display will make a beeping sound at relatively low frequency.
- If the object is greater than 0.5 m, but less than or equal to 2 ft. (0.8 m), the instrument cluster display will make a beeping sound at relatively high frequency.
- If the object is less than or equal to 0.5 m, the instrument cluster display will make a beeping sound at very high frequency.

NOTE:

The parking sensor system may not operate normally under the following conditions:

- If the sensor surface is covered with mud, ice, snow, or debris obstructing the sensor from functioning properly.
- If the vehicle is parked in extremely hot or cold environment for a long period of time.
- If driving on bumpy, gravel or grassy roads.

NOTE: (Continued)

- If close to another vehicle's horns, motorcycle engines and any other devices that may generate ultrasonic wave or radio communications device.
- If rain is falling on the sensor the rain drops can obstruct the sensor from working properly.
- If vehicle body is greatly inclined.
- If the sensor is covered in any way.
- If the sensor is knocked forcefully.
- If the vehicle is too close to objects that are narrow, too small or with sharp angles may also be difficult to detect.
- If the vehicle is backing up toward transparent objects.
- High objects with sharp or protruding angles.

CAUTION!

- The parking sensor does not remove the driver's responsibility of being appropriately careful and paying special attention while driving the vehicle!
- The parking sensor is only a parking aid and it is unable to recognize every obstacle, including small obstacles. Parking curbs might be temporarily detected or not detected at all. Obstacles located above or below the sensors will not be detected when they are in close proximity.
- The vehicle must be driven slowly when in reverse in order to be able to stop in time when an obstacle is detected.

WARNING!

- Drivers must be careful when backing up even with the parking sensor. Always check carefully around and behind your vehicle, check mirrors and be sure to check for pedestrians, animals, other vehicles, obstructions, and blind spots before backing up.
- You are responsible for safety and must continue to pay attention to your surroundings. Failure to do so can result in serious injury or death.

1

2

3

4

5

6

7

8

9

10

11

STARTING AND OPERATING

VEHICLE LOADING DESCRIPTIONS

Certification Label

As required by National Highway Traffic Safety Administration regulations, your vehicle has a certification label affixed to the driver side B-Pillar.

This label contains the month and year of manufacture, Gross Vehicle Weight Rating (GVWR), Gross Axle Weight Rating (GAWR) front and rear, and Vehicle Identification Number (VIN). The bar code that appears on the bottom of the label is the VIN.

Gross Vehicle Weight Rating (GVWR)

The GVWR is the total permissible weight of your vehicle including driver, passengers, vehicle, options and cargo. The label also specifies maximum capacities of front and rear axle systems (GAWR). Total load must be limited so GVWR and front and rear GAWR are not exceeded.

Payload

The payload of a vehicle is defined as the allowable load weight a vehicle can carry, including the weight of the driver, all passengers, options and cargo.

Gross Axle Weight Rating (GAWR)

The GAWR is the maximum permissible load on the front and rear axles. The load must be distributed in the cargo area so that the GAWR of each axle is not exceeded.

Each axle GAWR is determined by the components in the system with the lowest load carrying capacity (axle, springs, tires or wheels). Heavier axles or suspension components sometimes specified by purchasers for increased durability does not necessarily increase the vehicle's GVWR.

Tire Size

The tire size on the Vehicle Certification Label represents the actual tire size on your vehicle. Replacement tires must be equal to the load capacity of this tire size.

Rim Size

This is the rim size that is appropriate for the tire size listed.

Inflation Pressure

This is the cold tire inflation pressure for your vehicle for all loading conditions up to full GAWR.

Curb Weight

The curb weight of a vehicle is defined as the total weight of the vehicle with all fluids, including vehicle fuel, at full capacity conditions and with no occupants or cargo loaded into the vehicle. The front and rear curb weight values are determined by weighing your vehicle on a commercial scale before any occupants or cargo are added.

Loading

The actual total weight and the weight of the front and rear of your vehicle at the ground can best be determined by weighing it when it is loaded and ready for operation.

The entire vehicle should first be weighed on a commercial scale to insure that the GVWR has not been exceeded. The weight on the front and rear axles of the vehicle should then be determined separately to be sure that the load is properly distributed over the front and rear axles. Weighing the vehicle may show that the GAWR of either the front or rear axles has been exceeded but the total load is within the specified GVWR. If so, weight must be shifted from front to rear or rear to front as

appropriate until the specified weight limitations are met. Store the heavier items down low and be sure that the weight is distributed equally. Stow all loose items securely before driving.

Improper weight distributions can have an adverse effect on the way your vehicle steers and handles and the way the brakes operate.

WARNING!

- Properly secure all cargo with ropes or straps to help prevent it from sliding or shifting. Do not place cargo higher than the seatbacks. In a sudden stop or collision, unsecured cargo could cause personal injury.
- Overloading not only can shorten the life of your vehicle and the tire, but can cause unsafe vehicle handling and longer braking distances. This may cause a premature tire failure, which could result in a serious accident and personal injury. Failures caused by overloading are not covered by the vehicle's warranty.

CAUTION!

Do not load your vehicle any heavier than the GVWR or the maximum front and rear GAWR. If you do, parts on your vehicle can break, or it can change the way your vehicle handles. This could cause you to lose control. Also overloading can shorten the life of your vehicle.

DRIVING TIPS

Proper Use Of Vehicle

Proper use of vehicle involves using low power consumption by following the recommended usage to reduce wear and tear.

The following driving characteristics should be followed:

1. Avoid speeding

Avoid driving at high speeds. Follow all posted speed limits while driving. Driving at high speeds is dangerous and compromises the safety of your vehicle.

2. Uphill and hill starting

Make sure to engage the parking brake securely.

3. Downhill

Do not drive down a hill while the vehicle is engaged at NEUTRAL (N) gear, so that auxiliary braking capability of the motor will be maintained. Driving at an appropriate speed will avoid excessive wear of the brakes and ensure safer handling while driving. Sudden acceleration and emergency braking will waste energy, increase stress of mechanical parts and accelerate the wear of brakes and tires. Avoid excessive acceleration and braking whenever possible.

4. Smooth driving

Try to anticipate road conditions ahead of you to avoid unnecessary emergency driving action and hard braking. Smooth driving may reduce vehicle wear.

1

2

3

4

5

6

7

8

9

10

11

STARTING AND OPERATING

NOTE:

The vehicle has a calibration that will reduce the power level if driven at maximum speed for more than 30 minutes. This reduced power level will result in a reduction of the top speed and lower the throttle response of the vehicle. Depending on the grade of the roadway the vehicle might not be able to maintain steady speeds when the power is reduced. Maximum power can be restored by pulling over in a safe location and cycling the ignition OFF then back ON.

Attentive Driving

Before Starting the Vehicle

1. Properly adjust the seat and steering wheel positions as needed.
2. Adjust mirrors inside and outside the vehicle to ensure proper visibility around the vehicle.
3. Confirm that all doors have been closed and locked.
4. Fasten the safety belt.

During the Driving Process

1. Check for any warning or indicator lights and that instruments are operating normally during the driving process. If there are any abnormal vibrations, noises or abnormal smells in the vehicle, park at a safe location to determine the cause.
2. Avoid sudden acceleration or unnecessary emergency braking unless absolutely necessary.
3. The vehicle must be fully stopped before shifting to REVERSE (R) gear.

WARNING!

- Do not turn ignition off while driving, or the vacuum pump will stop working and the braking effect will be affected!
- Do not rotate or remove the key while driving, the steering wheel will lock up and a serious accident may occur!
- Do not shift the vehicle into NEUTRAL (N) position while driving on a downhill!

On-Road Driving Tips

Utility vehicles have higher ground clearance and a narrower track to make them capable of performing in a wide variety of off-road applications. Specific design characteristics give them a higher center of gravity than conventional passenger cars.

An advantage of the higher ground clearance is a better view of the road, allowing you to anticipate problems. Avoid making sharp turns or abrupt maneuvers. As with other vehicles of this type, failure to operate this vehicle correctly may result in loss of control or vehicle rollover.

Driving Through Slippery Surfaces

Information in this section will aid in safe and controlled driving in adverse weather and road conditions.

WARNING!

Rapid acceleration on slippery surfaces is dangerous. Unequal traction can cause sudden pulling of the front and rear wheels. You could lose control of the vehicle and possibly have a collision. Accelerate slowly and carefully whenever there is likely to be poor traction (ice, snow, wet, mud, loose sand, etc.).

Acceleration

- Rapid acceleration on snow covered, wet, or other slippery surfaces may cause the driving wheels to pull erratically to the right or left. This phenomenon occurs when there is a difference in the surface traction under the front and rear driving wheels.
- Avoid driving at high rates of speed, aggressive acceleration, or decelerating and sharp turns.
- Maintain a safe following distance between your vehicle and the vehicle in front of you, and carefully apply the brakes when braking.

Traction

When driving on wet or slushy roads, it is possible for a wedge of water to build up between the tire and road surface. This is hydroplaning and may cause partial or complete loss of vehicle control and stopping ability.

To reduce this possibility, the following precautions should be observed:

- Slow down during rainstorms or when the roads are slushy.
- Slow down if the road has standing water or puddles.
- Replace the tires when tread wear indicators first become visible.
- Keep tires properly inflated.
- Maintain sufficient distance between your vehicle and the vehicle in front of you to avoid a collision in a sudden stop.

Driving Through Water

If driving through standing water, use care to determine the water depth before proceeding. Driving through water more than a few inches (centimeters) deep will require extra caution to ensure safety and prevent damage to your vehicle.

Water Depth	Speed
5 inches (15 cm)	drive evenly at 6 mph (10 km/h)
9 inches (25 cm)	drive evenly at 3 mph (5 km/h)
Exceeds 11 inches (30 cm)	DO NOT DRIVE THROUGH

WARNING!

- Do not submerge the frame. The fusebox is attached to the frame and will short many critical circuits if submerged.
- Always check water depth before entering as a precaution. When driving through water, do not exceed 6 mph (10 km/h).
- Driving through water may cause damage that may not be covered by the vehicle warranty, or may result in loss of control of the vehicle or death.

1

2

3

4

5

6

7

8

9

10

11

HAZARD SWITCH	102
HIGH VOLTAGE BATTERY EMERGENCIES	103
ROADSIDE PROCEDURES	104
BULB REPLACEMENT	104
FUSE REPLACEMENT	105
Interior Power Distribution Fuses	106
Exterior Power Distribution Fuses	107
JUMP-STARTING (12-VOLT) BATTERY	108
JACKING AND TIRE CHANGING	110
Jacking Locations	111
Jacking Steps	112
Spare Tire And Winch	113
Wheel Installation	113
FREEING A STUCK VEHICLE	114
TOWING	115

1
2
3
4
5
6
7
8
9
10
11

IN CASE OF EMERGENCY

HAZARD SWITCH

The hazard switch is used to activate exterior lighting to indicate a hazard is present. Front, rear, left, and right turn indicators will flash when the hazard switch is activated.

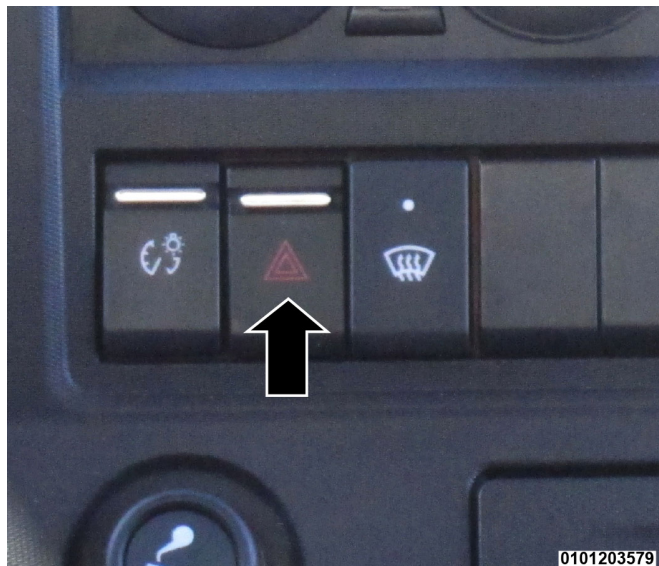

To activate the hazard indicators, push the hazard switch located in the panel of switches to the right of the steering wheel and under the climate controls. The exterior indicator lights will flash continuously.

To deactivate the hazard lights, push the hazard switch again.

This is an emergency warning system and should not be used when the vehicle is in motion. Use it when your vehicle is disabled and it is creating a safety hazard for other motorists.

NOTE:

With extended use, the hazard warning indicators may wear down your batteries.

WARNING!

- If stopping for an emergency, be sure to move the vehicle well off the road.
- Do not use the hazard warning flashers while moving on the highway unless unusual circumstances force you to drive so slowly that your vehicle might become a hazard to other traffic.
- Turn signals do not work when the hazard warning flasher lights are on.

HIGH VOLTAGE BATTERY EMERGENCIES

Emergency refers to any mechanical breakdown or accident while operating the vehicle.

What to do in an emergency?

1. Immediately stop the vehicle and open the door, leave the vehicle as soon as it is safe to do so.
2. Call 911

What to do if the battery gets extremely hot and begins to smoke while driving?

The driver must pay special attention to any high temperature warnings while operating the vehicle. If there is a peculiar smell or smoke coming out of batteries, perform the following:

1. Park the vehicle at roadside and if safe to do so, turn off the Master Switch to the the high voltage system.
2. Notify a Mullen authorized service provider for assistance.

WARNING!

The high voltage batteries have no parts that a non-Mullen authorized service provider can service.

- Under no circumstances should anyone open or tamper with the batteries.
- Always contact a Mullen authorized service provider to arrange for battery servicing.
- Do not attempt to open the battery boxes.

NOTE:

For service, maintenance, or inquiries, refer to the [Customer Assistance p. 162](#) chapter for contact information.

1

2

3

4

5

6

7

8

9

10

11

IN CASE OF EMERGENCY

ROADSIDE PROCEDURES

 **NOTE:**

For emergencies requiring immediate attention, call 911.
If your vehicle is not working, refer to the [Customer Assistance p. 162](#) chapter for service contact information.

BULB REPLACEMENT

Due to the nature of the exterior lights, it is recommended to have them replaced at a Mullen authorized service provider.

 **NOTE:**

For service, maintenance, or inquiries, refer to the [Customer Assistance p. 162](#) chapter for contact information.

FUSE REPLACEMENT

This vehicle is equipped with an interior and exterior fuse box.

Replacing Fuses

If you suspect a fuse is blown, please inspect the fuses carefully. If the drive motor system is not working, check for a blown fuse.

Replacement steps are as follows:

1. Remove the blown fuse
 - Place the vehicle in NEUTRAL (N) and securely engage the parking brake. Make sure the master switch and ignition switch are turned off.
 - Remove the fuse box panel cover. Interior fuse panel is located under the climate control dials. Exterior fuse panel is located behind the driver's side of the cab of the truck, below the master power switch.
 - Check the blown fuse type and cavity on the fuse box cover.
 - Remove and inspect the damaged fuse.
2. Installing a new fuse
 - If the fuse is blown, replace with a spare fuse found on the back of the cover panel. The spare fuse should be of the same amp rating and inserted in the same cavity.
 - Close the fuse box cover.

NOTE:

For service, maintenance, or inquiries, [Customer Assistance p. 162](#) chapter for contact information.

CAUTION!

When installing the fuse panel cover, it is important to ensure the cover is properly positioned and fully latched. Failure to do so may allow water to get into the power distribution center and possibly result in an electrical system failure.

WARNING!

- When replacing a blown fuse, always use an appropriate replacement fuse with the same amp rating as the original fuse. Never replace a fuse with another fuse of higher amp rating. The use of a fuse with a rating other than indicated may result in a dangerous electrical system overload. If a properly rated fuse continues to blow, it indicates a problem in the circuit that must be corrected. Never replace a blown fuse with metal wires or any other material. Do not place a fuse inside a circuit breaker cavity or vice versa. Failure to use proper fuses may result in serious personal injury, fire and/or property damage.
- Before replacing a fuse, make sure that the ignition switch is OFF and that the master switch is turned OFF, all the other accessories are switched off and/or disengaged.
- If the replaced fuse blows again, contact a Mullen authorized service provider.
- Do not reuse blown or damaged fuses. This can damage the vehicle or cause a fire.
- Fuses relating to high voltage or safety systems must be serviced by a Mullen authorized service provider.

1

2

3

4

5

6

7

8

9

10

11

IN CASE OF EMERGENCY

Interior Power Distribution Fuses

The interior fuse box is located behind an access panel in the lower, center area of the instrument panel and contains fuses and relays.



0101201686

Interior Fuse Panel Location

Diagram labels: BLOWER RELAY, HIGH BEAM RELAY, FRONT FOG LAMP RELAY, FUEL RELAY, ILLUMINE RELAY, LOW BEAM RELAY, MIRROR HEATER RELAY, DRL RELAY, REVERSE LAMP RELAY, FUSE PULLER, SPARE FUSE.

WARNING

MUST USE SPECIFIED FUSES AND RELAYS, OTHERWISE IT MAY CAUSE FIRE OR EQUIPMENT FAILURE.

FL1	40A	BLOWER
FL2		
FL3		
FL4		
FL5		

AGIB-303X-AC
*OPTIONAL

F1 5A	IGNITION SIGNAL	F11 5A	A/C CONTROL	F21 5A	IP CLUSTER	F31 5A	REMOTE MONITORING
F2 10A	VCU	F12 5A	IG2	F22 15A	HAZARD LAMP	F32 10A	INDOOR LAMP/DIAGNOSIS
F3 5A	REVERSE LAMP	F13 15A	WIPER/WASHER	F23 5A	RADIO	F33 7.5A	DRIVE RECORDER *
F4 5A	ABS	F14 5A	MIRROR *	F24 5A	BACKGROUND LIGHT	F34 10A	LEFT LOW BEAM
F5 5A	IP CLUSTER / BCM	F15 5A	RADIO	F25 7.5A	POSITION LAMP	F35 10A	RIGHT LOW BEAM
F6 5A	DCDC	F16 15A	CIGAR	F26 5A	DRL *	F36 15A	LEFT HIGH BEAM
F7 7.5A	DRIVE RECORDER *	F17 10A	VCU	F27		F37 15A	RIGHT HIGH BEAM
F8 5A	Gateway	F18 10A	PEDESTRIAN REMINDER	F28 10A	Gateway	F38 5A	POSITION LAMP
F9		F19 20A	RIGHT FRONT WINDOW	F29 10A	BCM	F39 15A	FRONT FOG LAMP
F10 5A	START SIGNAL	F20 20A	LEFT FRONT WINDOW	F30 10A	CENTRAL LOCK	F40 5A	STOP LAMP

0101203153

Interior Fuse Label

Exterior Power Distribution Fuses

The exterior fuse box is located outside of the cab, behind the driver's side of the vehicle and below the master power switch. The fuse box contains cartridge fuses, micro fuses, relays, and circuit breakers.

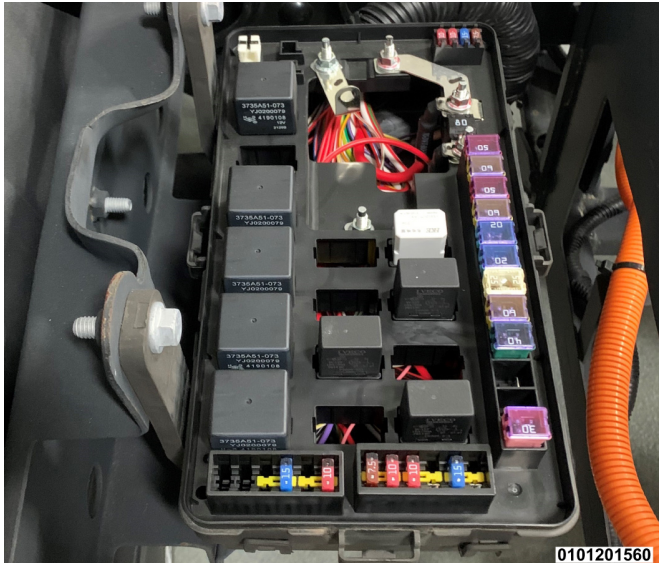

Exterior Fuse Location

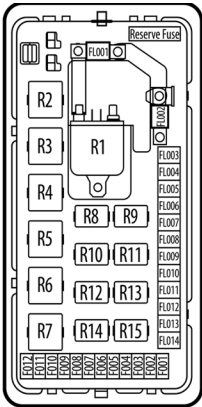

	Name	Specifications
R1		
R2	Main Relay	40A
R3		
R4	Vacuum Pump Relay	40A
R5	Horn Relay	40A
R6	Radiator Low-speed Fan Relay	40A
R7	Radiator High-speed Fan Relay	70A
R8		
R9		
R10		
R11	Water Pump Relay	30A
R12	BMS Relay	30A
R13		
R14	BMS relay	30A
R15		

△ Warning: MUST USE SPECIFIED FUSES AND RELAYS OTHERWISE IT MAY CAUSE FIRE OR EQUIPMENT FAILURE.

	Name	Specifications
FLO01		
FLO02	Radiator High-speed Fan	80A
FLO03	Ignition Switch	50A
FLO04	Vacuum Pump	60A
FLO05	Light	60A
FLO06	Cab	60A
FLO07	ABS Motor	20A
FLO08	ABS Valve	20A
FLO09	Main Relay	30A
FLO10	Radiator Low-speed Fan	60A
FLO11	HICU	40A
FLO12	BMS	20A
FLO13		
FLO14	Constant Electricity	30A
F001	OBC/EVCC	15A
F002	Cooling Water Pump	15A
F003	TMS Relay Coil Power Supply	5A
F004	VCU	10A
F005	BMS	10A
F006	Chassis Power Take-off	7.5A
F007	MCU	10A
F008	Horn	15A
F009		
F010		
F011		
F012		

△ Warning: MUST USE SPECIFIED FUSES AND RELAYS OTHERWISE IT MAY CAUSE FIRE OR EQUIPMENT FAILURE. 0101201850

Exterior Fuse Label

- 1
- 2
- 3
- 4
- 5
- 6
- 7
- 8
- 9
- 10
- 11

IN CASE OF EMERGENCY

JUMP-STARTING (12-VOLT) BATTERY

If a vehicle will not start, use another 12-volt battery to jump start the vehicle.

If the READY indicator does not display after attempting to jump start the vehicle, make sure the 12-volt battery is fully charged and fully charge the vehicle's high voltage battery. See [High Voltage Charging p. 18](#) for charging the high voltage battery. If the READY indicator still does not display after these steps, seek authorized Mullen service.

NOTE:

For service, maintenance, or inquiries, [Customer Assistance p. 162](#) chapter for contact information.

Symptom	Possible Cause	Correction
The instrument panel does not light up when the key is turned to ON.	The 12-volt battery is discharged.	Jump-start the vehicle with an alternate 12-volt battery.

The low voltage battery provides initial power to turn on the vehicle. If the 12-volt battery becomes depleted, the vehicle cannot start without another power source. Unlike jump-starting a gasoline powered vehicle, which requires considerable power to crank a starter motor, Mullen THREE electric vehicles only require enough power to switch the power on. When jump-starting these vehicles, there is no need to wait for the 12-volt battery to charge before starting the

vehicle. As soon as a charged battery is connected with jumper cables, the vehicle can be started. The high voltage battery will begin recharging the low voltage battery as soon as the vehicle is started.

WARNING!

- If the operator is unfamiliar with the jump-starting process, it is advisable to have someone assist who has experience jump-starting electric vehicles. Ask your fleet manager to have a technician demonstrate the correct jump-starting process.
- Only 12-volt batteries can be used for jump-starting.
- Do not touch the on-board charging system during charging or jump-starting.
- Use high quality jumper cables and ensure their insulation is not frayed or damaged.
- Keep jumper cable clamps away from any objects that are near the battery. Do not allow clamps to touch each other or any metal except for the correct battery terminals and vehicle grounding point.

NOTE:

The vehicle cannot be "push-started".

To access the low voltage (12-volt) battery, you will need to lift the cab. See [Tilting And Lowering The Cab p. 118](#) in the Maintenance and Service section of this manual.

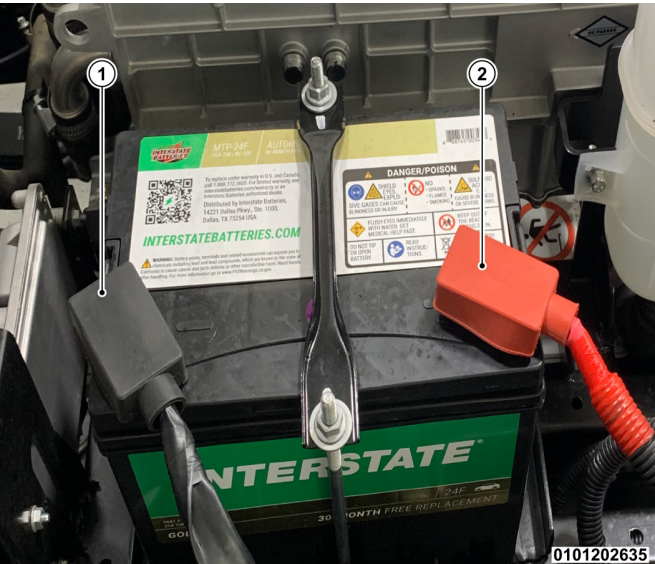

- 1. Negative Post (black)
- 2. Positive Post (red)

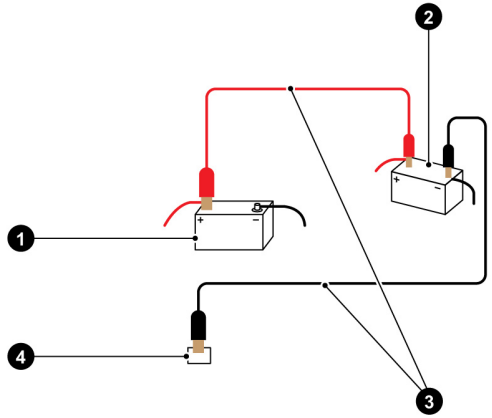

- 1. Dead Battery
- 2. Good Battery
- 3. Jumper Cables
- 4. Body Ground

0101202859

1
2
3
4
5
6
7
8
9
10
11

IN CASE OF EMERGENCY

To jump-start the vehicle with another vehicle, follow these steps:

1. Turn off all lights and accessories in both vehicles. If the charged battery is in another vehicle, do not allow the two vehicles to touch.
2. Engage the parking brake fully, then shift the gear shifter into NEUTRAL (N) on the uncharged vehicle.
3. Turn the ignition key to the LOCK position on the uncharged vehicle.
4. Connect the positive terminals of both batteries (the charged battery and the dead battery) with the red jumper cables.
5. Connect the black cable to the negative terminal of the charged battery.
6. Connect the other end of the black cable to a secure metal grounding point on the body of the uncharged vehicle, away from the battery.
7. Try starting the uncharged vehicle. If it does not start, check your jumper cable connections.
8. Once the uncharged vehicle starts, turn off the other vehicle.
9. Remove the negative (black) jumper cables then remove the positive (red) jumper cables.

Determine the cause of the battery becoming drained. Possible causes include head lights or accessories left on. If the cause is not apparent, have the vehicle serviced.

NOTE:

For service, maintenance, or inquiries, [Customer Assistance p. 162](#) chapter for contact information.

JACKING AND TIRE CHANGING

WARNING!

- Do not attempt to change a tire on the side of the vehicle close to moving traffic. Pull far enough off the road to avoid the danger of being hit when operating the jack or changing the wheel.
- Being under a jacked-up vehicle is dangerous. The vehicle could slip off the jack and fall on you. You could be crushed. Never put any part of your body under a vehicle that is on a jack. If you need to get under a raised vehicle, take it to a service center where it can be raised on a lift.
- Never start the vehicle while it is on a jack.
- The jack is designed to be used as a tool for changing tires only. The jack should not be used to lift the vehicle for service purposes. The vehicle should be jacked on a firm level surface only. Avoid ice or slippery areas.

Jacking Locations



Front Axle Lifting Position

Jacking locations for the front of the vehicle will be under each front axle.



Rear Axle Lifting Position

Jacking locations for the rear of the vehicle will be under each rear axle.

1
2
3
4
5
6
7
8
9
10
11

IN CASE OF EMERGENCY

Jacking Steps

WARNING!

Carefully follow these tire changing warnings to help prevent personal injury or damage to your vehicle:

- Do not attempt to change a tire on the side of the vehicle close to moving traffic. Pull far enough off the road to avoid being hit when operating the jack or changing the wheel.
- Always park on a firm, level surface as far from the edge of the roadway as possible before raising the vehicle.
- Turn on the hazard warning flashers.
- Apply the parking brake firmly and set the transmission in NEUTRAL (N).
- Block the wheel diagonally opposite the wheel to be raised.
- Never start or run the vehicle on a jack.
- Do not let anyone sit in the vehicle when it is on a jack.
- Do not get under the vehicle when it is on a jack. If you need to get under a raised vehicle, take it to a Mullen authorized service provider where it can be raised on a lift.
- Only use the jack in the positions indicated and for lifting this vehicle during a tire change.
- If working on or near a roadway, be extremely careful of motor traffic.
- To assure that spare tires, flat or inflated, are securely stowed under the vehicle, spares must be stowed with the valve stem facing the ground.

NOTE:

For service, maintenance, or inquiries, refer to the [Customer Assistance p. 162](#) chapter for contact information. Passengers should not remain in the vehicle when the vehicle is being raised or lifted.

1. Park the vehicle on a firm, level surface as far from the edge of the roadway as possible. Avoid icy or slippery areas.
2. Put the gear selector in NEUTRAL (N) and apply the parking brake.
3. Turn on the hazard warning flashers.
4. Turn OFF the vehicle.
5. Block both front and rear of the wheel diagonally opposite of the jacking position. For example, if changing the left front wheel, block the right rear wheel.
6. Position the jack under the jacking point, near the axle, of the tire being replaced and raise the vehicle to a point at which the tire is still touching the ground.
7. Slightly loosen the wheel lug nuts by turning them counterclockwise. Do not remove the lug nuts.
8. Jack up the vehicle until the tire is just clear of the ground.
9. Remove the wheel lug nuts and then the wheel.
10. To remove the wheels of a rear dual-wheel, first loosen the outer wheel lug nuts and remove the outer wheel then lower the jack. Then loosen the inner wheel lug nuts and jack up the vehicle again to remove the inner wheel.

Spare Tire And Winch

The spare tire is located under the frame on the rear of the vehicle.

1. When the spare tire is needed, locate the handle for the winch on the rear passenger's side of the vehicle, on the frame.
2. Unscrew the locking threaded sleeve on top of the winch, rotate the handle on the right side of the vehicle frame counter-clockwise with the wrench, to lower the spare tire.
3. When raising the spare tire with the winch, turn the handle clockwise to the final position to firmly fix the spare tire on the vehicle frame and tighten the locking threaded sleeve.

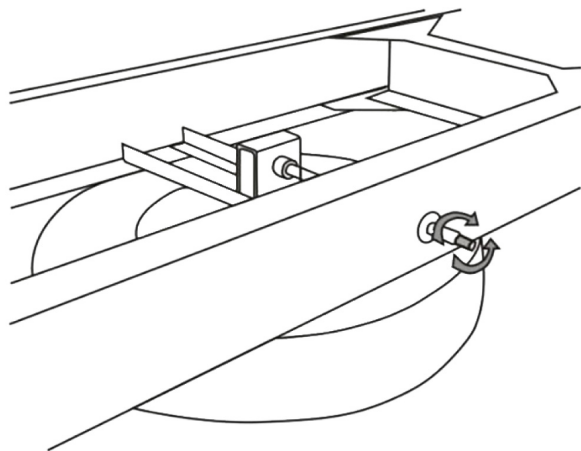

0101201486

Wheel Installation

1. Clean the following tire and wheel components before mounting the wheel. If they are dirty, the wheel nuts could become loose during driving:
 - Threads on wheel studs and lug nuts.
 - Tapered surface of wheel lug nuts.
 - Lug wheel mounting surface.
 - Lug wheel mating surface.
 - Wheel nut contact surface on disc wheel.
 - Lug wheel inside surface.
 - Guide surfaces on hub.

If a wheel stud is damaged, replace all the wheel studs and wheel lug nuts of that wheel.

When the tires or the wheels have been replaced or removed and reinstalled, have the wheel balanced.

2. Mount the wheel so that the wheel studs line up with the bolt holes in the wheel. Then, tighten the wheel lug nuts to hold the wheel in position. If the lug nut has a tapered end, place the tapered end toward the wheel.

NOTE:

. When mounting dual rear wheels, make sure the valve stems are approximately 180 degrees from each other.

3. Lower the vehicle until the tire makes contact gently with the ground.
4. Tighten the wheel lug nuts. See "[Wheel And Tire Torque Specifications p. 155](#)" for proper torque adjustment.

1

2

3

4

5

6

7

8

9

10

11

IN CASE OF EMERGENCY

WARNING!

- Fit the socket wrench securely on the wheel nut. If fitted improperly, the wrench will slip off the nut, and could cause injury.
- Do not jump or jerk on the wrench handle when tightening the nut by using your own weight. Doing so can overtighten the nut. Overtightening the nuts could overstrain the bolts or deform the disc wheel's surface.
- The wheel nuts must be tightened to the specified torque. If the nuts are tightened loosely or too tight, parts may be damaged and wheels may come off. This can damage the vehicle and cause physical injury.

Make sure to safely stow all jacking tools and the damaged tire before driving.

FREEING A STUCK VEHICLE

If your vehicle becomes stuck in mud, sand, or snow, it can often be moved using a rocking motion. Turn the steering wheel right and left to clear the area around the front wheels. Then shift back and forth between DRIVE (D) and REVERSE (R), while gently pressing the accelerator. Use the least amount of accelerator pedal pressure that will maintain the rocking motion without spinning the wheels.

CAUTION!

- Pressing too hard on the accelerator and spinning the wheels may lead to overheating and failure. Allow the vehicle to cool in NEUTRAL for at least one minute after every five rocking-motion cycles. This will minimize overheating and reduce the risk of failure during prolonged efforts to free a stuck vehicle.
- When "rocking" a stuck vehicle by shifting between DRIVE (D) and REVERSE (R). Do not spin the wheels faster than 15 mph (24 km/h) or drivetrain damage may result.
- Make sure to lift foot off of accelerator when shifting between DRIVE (D) and REVERSE (R).
- Pressing too hard on the accelerator and spinning the wheels too fast may lead to overheating and failure. It can also damage the tires. Do not spin the wheels above 30 mph (48 km/h) while in gear.

WARNING!

To avoid vehicle damage, serious personal injury or death when recovering a stuck vehicle:

- Contact a professional towing service to recover the vehicle if you have any questions regarding the recovery procedure.
- Tow chains or cables must be attached only to main structural members of the vehicle.
- Do not use the vehicle tie-downs to tow or free a stuck vehicle.
- Only use devices specifically designed for vehicle recovery and follow the manufacturer's instructions.
- Always pull the recovery device straight out from the front of the vehicle. Never pull at an angle.
- Route recovery devices so they do not touch any part of the vehicle except the attachment point.

TOWING

CAUTION!

When towing the vehicle, only use a Flatbed trailer or tow from the front wheels. Towing from the rear wheels can damage the vehicle.

If the vehicle becomes disabled and requires towing make sure to do the following:

1. Make sure the gear shift lever is in NEUTRAL (N) position and the parking brake is disengaged.
2. Disengage high voltage components by turning master switch to OFF position.

If the vehicle needs to be dragged:

1. Tow strap and drag bar
 - The most suitable and safest towing method is to use a drag bar. Only when the drag bar is unavailable can a tow strap be used.
 - The tow strap is an artificial fiber rope or a rope made from a similar elastic materials.
 - The tow strap or drag bar can only be connected onto the rear tow hook.
2. Precautions for towing
 - Only move the vehicle when the tow strap is tensioned.
 - Turn the ignition switch ON to prevent the steering wheel from being locked and turn on the hazard lights.
 - Check the instrument panel display, if no warning lights are illuminated, the vehicle can be towed. If warning lights are illuminated on the instrument panel display, remove the drive shaft before towing. Otherwise, remove the axle shaft on one side of vehicle.
 - The tow strap must always keep tension.

1

2

3

4

5

6

7

8

9

10

11

IN CASE OF EMERGENCY

3. Operation method

- It is recommended to contact a towing company for towing the vehicle. Expert level skills are needed when a traction rope is used.
- Keep in mind the road conditions you are towing on and adjust your driving to the conditions.



0101203130

Rear Tow Hook

The rear tow hook is located on the back edge of the frame on the passenger side.

⚠ WARNING!

- Do not tow the disabled vehicle with a broken or malfunctioning steering system.
- When towing a vehicle, shift the disabled vehicle into NEUTRAL (N) gear.
- If towing distance exceeds 62 miles (100 km), or flat towing, remove the drive shaft from the connecting flange.

⚠ NOTE:

- Please observe related laws and regulations.
- The hazard lights on the tow vehicle and the vehicle being towed needs to be activated and flashing.
- If the vehicle cannot be towed normally, it needs to be towed on a flatbed.

MAINTENANCE AND SERVICE

TILTING AND LOWERING THE CAB 118

VEHICLE MAINTENANCE 122

DAILY MAINTENANCE 123

MAINTENANCE INTERVALS 124

WINDSHIELD WASHER FLUID RESERVOIR 128

 Wiper Blade Removal 128

BRAKE FLUID RESERVOIR 129

POWER STEERING FLUID RESERVOIR 130

VEHICLE WHEELS AND TIRES 131

 Tire Safety Information 133

 Tire Markings 133

 Tires — General Information 134

 Tire Types 138

 Wheel And Wheel Trim Care 139

 Tire Chains / Traction Devices 140

 Tire Rotation Recommendations 140

DEPARTMENT OF TRANSPORTATION UNIFORM TIRE QUALITY GRADES 142

 Temperature Grades 142

 Traction Grades 142

FUSE AND RELAY MAINTENANCE 143

LOW VOLTAGE BATTERY MAINTENANCE AND STORAGE 144

OPERATION AND MAINTENANCE OF THE HIGH VOLTAGE BATTERIES 144

COOLING SYSTEM MAINTENANCE 147

INTERIOR AND EXTERIOR CLEANING 149

 Exterior Cleaning 149

 Interior Cleaning 151





 Cleaning Cabin Air Filter 151

1
2
3
4
5
6
7
8
9
10
11

TILTING AND LOWERING THE CAB

The cab is equipped with a column-assist, single-torsion-bar, and lifting mechanism. If the cab lifting mechanisms require adjustments, refer to the [Customer Assistance p. 162](#) chapter for service contact information.

You will find a basic cab tilting and lowering instruction label on the vehicle near the mechanisms.

 CAUTION 	
TO HELP AVOID PERSONAL INJURY TILTING CAB	
1. PARK VEHICLE ON LEVELED GROUND AND ENSURE THERE IS AMPLE SPACE AROUND CAB BEFORE TILTING.	
2. BLOCK FRONT WHEELS, PLACE THE GEARSHIFT LEVER IN NEUTRAL OR "P" (IF EXISTS), AND SET THE PARKING BRAKE FIRMLY.	
3. REMOVE ALL OBJECTS FROM INSTRUMENT PANEL, SEATS, AND CAB FLOOR.	
4. ALWAYS INSERT THE LOCK PIN INTO THE CAB SUPPORT WHEN CAB IS IN RAISED POSITION.	
5. MAKE SURE THE LOCK HOOK ATTACHED TO THE HANDLE HAS BEEN FIRMLY ENGAGED.	
SEE OWNER'S MANUAL FOR DETAILS	
	CAB TILTING PROCEDURE <ol style="list-style-type: none">1. GRAB ASSIST HANDLE "D" AND LEVER "A" WITH LEFT HAND. PULL LEVER "A" TOWARDS ASSIST HANDLE "D" BY SQUEEZING HAND. WHILE LEVER "A" IS SQUEEZED, PULL HANDLE "D" UP WITH RIGHT HAND.2. TO PREVENT AN ABRUPT CAB LIFT HOLD THE ASSIST HANDLE "D" WHILE PULLING THE SAFETY HOOK "B".3. RAISE THE CAB TO ITS FULL LIFT POSITION AND ENSURE THAT THE LOCK LEVER "E" IS FIRMLY LOCKED.4. INSERT THE LOCK PIN "C" IN THE CAB SUPPORT.
	 TO LOWER THE CAB <ol style="list-style-type: none">1. REMOVE THE LOCK PIN "C" FROM THE CAB SUPPORT.2. WHILE HOLDING THE ASSIST HANDLE "D" UNLOCK THE LOCK LEVER "E". BE AWARE OF THE CAB COMING DOWN.3. LOWER THE CAB BY MEANS OF THE ASSIST HANDLE UNTIL THE SAFETY HOOK "B" IS ENGAGED.4. ROTATE THE HANDLE "D" DOWNWARDS UNTIL THE LEVER ENGAGES WITH THE LOCK HOOK "F".

AGID 300X AG 0101202619

NOTE:

- When tilting the cab, the vehicle must be fully stopped with the parking brake securely engaged on level ground, and the vehicle must be in NEUTRAL (N) gear.
- Make sure to tilt the cab in a flat and open area; when tilting the cab indoors, make sure enough front and overhead space is considered prior to unlatching the cab.
- The parking brake must be applied firmly, gear shift must be in NEUTRAL (N) and wheels should be blocked with block wedges to prevent rolling or shifting.
- Make sure the cab doors are fully closed. Do not place anything on the instrument panel, seats or floor.

Locate the cab release handles on the lower exterior of the cab, to the right of the driver's side door.

Cab Tilting Procedure

Place your left hand through the stationary black cab handle (1) and grasp the gold latch release bar (2) simultaneously. With your right hand, pull back and toward you on the cab release lever (3). Then use the right hand, once the cab lever is released, to pull the safety release (4) straight toward you.

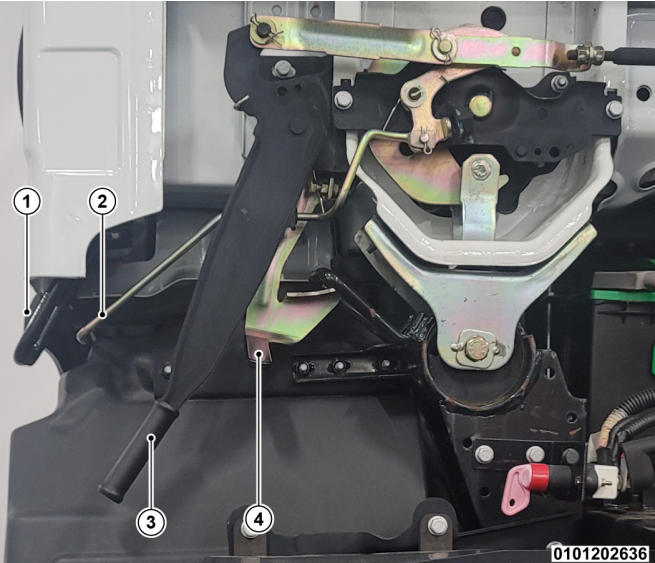

While holding the stationary black cab handle (1) to lift, and tilt the cab upwards.

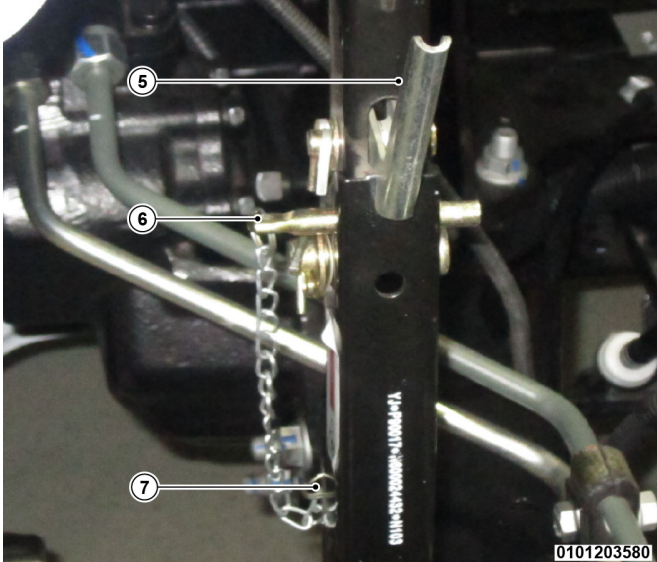

Make sure that when the cab is lifted, the cab safety support (5) is locked into place. Then remove the lock out key (7) and insert the lock out key into key hole (6) to secure cab in place.

1
2
3
4
5
6
7
8
9
10
11



Lock Out Key Hole

⚠ WARNING!

After lifting the cab, make sure to secure the raised cab with the safety lockout key (7) in the lockout key hole (6), so as to avoid loss of life and personal injuries or damage to the vehicle.

Cab Lowering Procedure

To lower the cab and secure it in driving position, make sure to do the following:

⚠ WARNING!

When releasing the cab safety support (5), use caution to avoid pinch points. Moving parts can cause severe personal injury.

Hold the stationary black cab handle (1) with your left hand to support the cab, pull out safety lockout key from the key hole (6). Snap lockout key back into holder (7), then pull back to unlock the cab safety support (5) with your right hand.

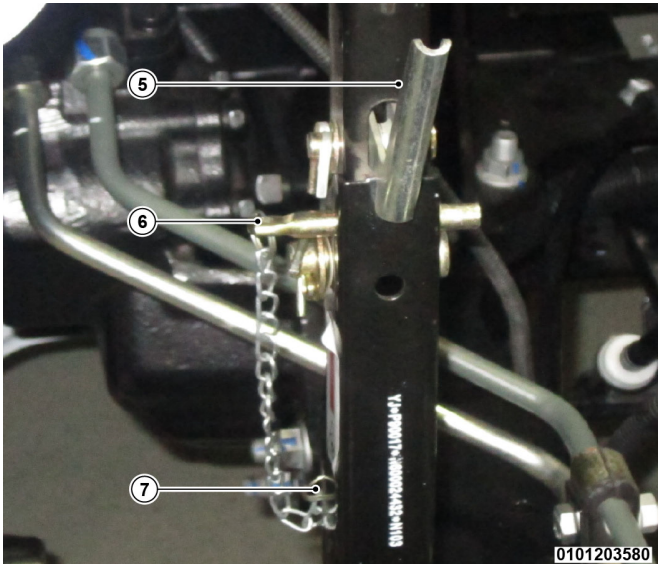
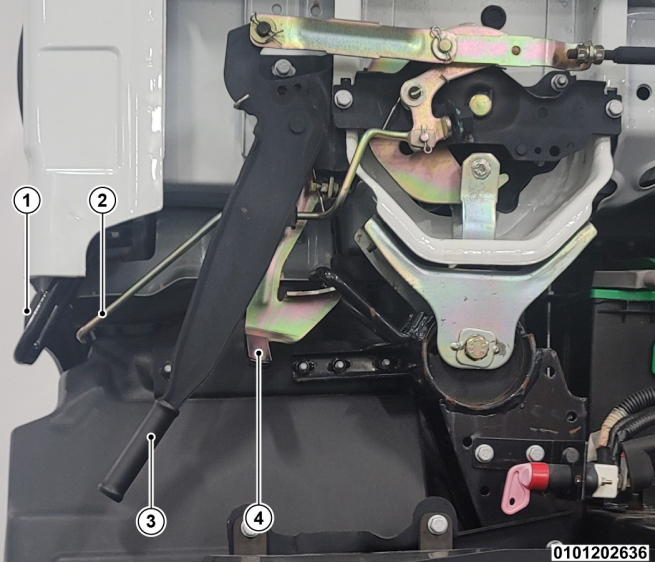

While holding the stationary black cab handle (1) pull down firmly, lowering the cab down until latched. Then push down and away from you on the cab release lever (3) to secure the cab.

1
2
3
4
5
6
7
8
9
10
11

WARNING!

- Pay extra attention to cab, handle (3) and placement of hands when pulling down the cab to avoid personal injuries from moving parts.
- After resetting the cab, double check that the cab is securely latched in place.

VEHICLE MAINTENANCE

Vehicle maintenance is necessary to keep your vehicle in good working order. Regularly scheduled maintenance is essential to extend the life and reduce operating costs of the vehicle.

For the early detection of faults, troubleshooting, and reducing maintenance costs, follow the maintenance schedule intervals.

NOTE:

For service, maintenance, or inquiries, refer to the [Customer Assistance p. 162](#) chapter for contact information.

WARNING!

When conducting regular inspection and maintenance on the vehicle, injuries and vehicle damage must be avoided.

- Park the vehicle on smooth road, and place the gear shift lever in NEUTRAL (N) position, apply the parking brake and wedge wheels to prevent the vehicle from moving.
- When doing self-maintenance, do not place the key in “ON” position.
- Do not attempt to repair the high voltage system, see Customer Assistance chapter for service or repairs.
- Please keep your hands, clothes, hair and tools far away from moving parts.

WARNING! (Continued)

- The lifting jack should only be used for changing a flat tire. Do not go under the vehicle while using the jack.
- If the ignition is ON, do not disconnect any electrical connections.
- Serious injuries, death or vehicle damages may occur if warnings are not followed.

DAILY MAINTENANCE

- Check tires/tire pressure
- Check brakes/parking brake
- Check lights
- Check fluid levels

NOTE:

For service, maintenance, inquiries, or if abnormal conditions exist refer to the [Customer Assistance p. 162](#) chapter for contact information.

1

2

3

4

5

6

7

8

9

10

11

MAINTENANCE AND SERVICE

MAINTENANCE INTERVALS

Routine maintenance includes inspecting, repairing and adjusting the vehicle at regular intervals. This helps keep the vehicle in good working condition and ensures the safety and comfort of the occupants.

NOTE:

- Service Intervals are based on Months or Miles whichever occurs first.
- For service, maintenance, or inquiries, refer to the [Customer Assistance p. 162](#) chapter for contact information.

Maintenance Intervals

Mileage (km) or time passed *(whichever comes first)	500 mi (804 km)	5,000 mi (8,046 km)	10,000 mi (16,093 km)	15,000 mi (24,140 km)	20,000 mi (32,186 km)	25,000 mi (40,233 km)	30,000 mi (48,280 km)	35,000 mi (56,327 km)	40,000 mi (64,373 km)	45,000 mi (72,420 km)	50,000 mi (80,467 km)	55,000 mi (88,513 km)	60,000 mi (96,560 km)	65,000 mi (104,607 km)	70,000 mi (112,654 km)	75,000 mi (120,700 km)	80,000 mi (128,747 km)	85,000 mi (136,794 km)	90,000 mi (144,840 km)	95,000 mi (152,887 km)	100,000 mi (160,934 km)	
Maintenance Activity																						
Check and lift the cab, check its cab tilting force and adjust if necessary. *(or every 6 months)		X	X	X	X	X	X	X	X	X	X	X	X	X	X	X	X	X	X	X	X	X
Grease Various Zerk Fittings *(or every 6 months)		X	X	X	X	X	X	X	X	X	X	X	X	X	X	X	X	X	X	X	X	X
Inspect Brake System *(or every 6 months)		X	X	X	X	X	X	X	X	X	X	X	X	X	X	X	X	X	X	X	X	X

MAINTENANCE AND SERVICE

Mileage (km) or time passed *(whichever comes first)	500 mi (804 km)	5,000 mi (8,046 km)	10,000 mi (16,093 km)	15,000 mi (24,140 km)	20,000 mi (32,186 km)	25,000 mi (40,233 km)	30,000 mi (48,280 km)	35,000 mi (56,327 km)	40,000 mi (64,373 km)	45,000 mi (72,420 km)	50,000 mi (80,467 km)	55,000 mi (88,513 km)	60,000 mi (96,560 km)	65,000 mi (104,607 km)	70,000 mi (112,654 km)	75,000 mi (120,700 km)	80,000 mi (128,747 km)	85,000 mi (136,794 km)	90,000 mi (144,840 km)	95,000 mi (152,887 km)	100,000 mi (160,934 km)
Inspect Fluid Levels *or every 6 months	X	X	X	X	X	X	X	X	X	X	X	X	X	X	X	X	X	X	X	X	X
Rotate Tires *or every 6 months		X	X	X	X	X	X	X	X	X	X	X	X	X	X	X	X	X	X	X	X
Lubricate Locks, Latches, and Hinges *or every 6 months		X	X	X	X	X	X	X	X	X	X	X	X	X	X	X	X	X	X	X	X
Inspect Wiper Blades *or every 12 months			X		X		X		X		X		X		X		X		X		X
Inspect Steering Mechanism *or every 12 months				X			X			X			X			X			X		
Inspect Brake Lines *or every 12 months	X			X			X			X			X			X			X		
Inspect Radiator Lines *or every 12 months				X			X			X			X			X			X		
Inspect Radiator and Condenser *or every 12 months				X			X			X			X			X			X		

1

2

3

4

5

6

7

8

9

10

11

MAINTENANCE AND SERVICE

Mileage (km) or time passed *(whichever comes first)	500 mi (804 km)	5,000 mi (8,046 km)	10,000 mi (16,093 km)	15,000 mi (24,140 km)	20,000 mi (32,186 km)	25,000 mi (40,233 km)	30,000 mi (48,280 km)	35,000 mi (56,327 km)	40,000 mi (64,373 km)	45,000 mi (72,420 km)	50,000 mi (80,467 km)	55,000 mi (88,513 km)	60,000 mi (96,560 km)	65,000 mi (104,607 km)	70,000 mi (112,654 km)	75,000 mi 120,700 km)	80,000 mi (128,747 km)	85,000 mi (136,794 km)	90,000 mi (144,840 km)	95,000 mi (152,887 km)	100,000 mi (160,934 km)	
Inspect Rear Driveline *or every 12 months				X			X			X			X			X			X			
Inspect 12-Volt Battery *or every 12 months							X			X			X			X			X			
Inspect Suspension System *or every 12 months							X			X			X			X			X			
Flush and Refill Coolant *or every 12 months							X			X			X			X			X			
Flush Brake Fluid *or every 12 months								X									X					
Replace Differential Fluid *or every 12 months			X					X									X					
Inspect Exterior Lighting *or every 12 months								X									X					

MAINTENANCE AND SERVICE

Mileage (km) or time passed *(whichever comes first)	500 mi (804 km)	5,000 mi (8,046 km)	10,000 mi (16,093 km)	15,000 mi (24,140 km)	20,000 mi (32,186 km)	25,000 mi (40,233 km)	30,000 mi (48,280 km)	35,000 mi (56,327 km)	40,000 mi (64,373 km)	45,000 mi (72,420 km)	50,000 mi (80,467 km)	55,000 mi (88,513 km)	60,000 mi (96,560 km)	65,000 mi (104,607 km)	70,000 mi (112,654 km)	75,000 mi 120,700 km)	80,000 mi (128,747 km)	85,000 mi (136,794 km)	90,000 mi (144,840 km)	95,000 mi (152,887 km)	100,000 mi (160,934 km)	
Inspect Wheel Alignment *or every 12 months	X				X				X				X				X					X
Inspect Connection Bolts on Rear Driveline, Steering, and Suspension *or every 12 months	X																					
Inspect Spare Tire *or every 12 months							X						X						X			
Rust Inhibitor Application	Annually																					

1
2
3
4
5
6
7
8
9
10
11

WINDSHIELD WASHER FLUID RESERVOIR



1. Washer fluid reservoir cap
2. Washer fluid reservoir window

The windshield washer fluid reservoir access is located on the right side of the instrument panel, near the passenger side door frame. Remove the panel cover to access the windshield washer fluid reservoir. The fill capacity of the reservoir tank is 1.05 quarts (1.5L), fill the tank until full. See, [Fluids, Capacities And Lubricants p. 159](#) for additional information. It is not possible to see the remaining amount of windshield washer fluid at the bottom of the reservoir. Please frequently fill windshield washer fluid according to your personal usage and fill to the top of the tank.

⚠ WARNING!

Worn and dirty wiper blades will affect visibility through the windshield. Regularly clean the wiper blades and the windshield. Avoid using the windshield wipers when the windshield is dry. Avoid operating the wiper fluid spray motor for long periods of time.

Wiper Blade Removal

Eventually, your vehicles wiper blades will need to be replaced.

Removing a wiper blade

1. Lift up on either wiper blade arm and move it away from the vehicle until it stays up.
2. Rotate the wiper blade around until it stops.
3. Using one hand to support the wiper blade arm, use your other hand to push down on the center of the wiper blade, pushing towards the vehicle.



4. The wiper blade should give and release from the wiper blade arm.

Installing a wiper blade

1. Make sure the wiper blade arm is in the raised position.
2. Follow the steps for removing a wiper blade in reverse.
3. When the wiper blade is installed, rotate the blade to its normal position and gently lower the wiper blade arm to the vehicle.

BRAKE FLUID RESERVOIR



The brake fluid reservoir access panel is located on the driver's side of the instrument panel, near the door frame.

NOTE:

Be sure to use only DOT 4 brake fluid and clean the filler cap before removing. See, [Fluids, Capacities And Lubricants p. 159](#) for additional information.

1
2
3
4
5
6
7
8
9
10
11

MAINTENANCE AND SERVICE

POWER STEERING FLUID RESERVOIR

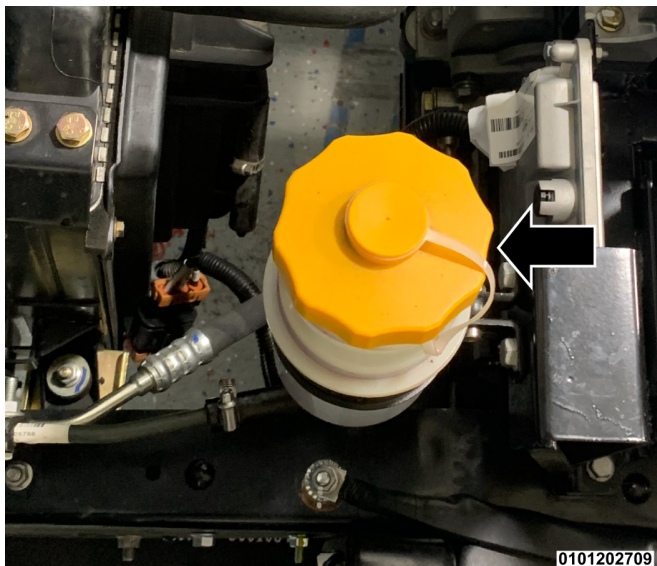

The power steering fluid reservoir is located under the cab, on the driver side, to the left of the low voltage battery. See [Tilting And Lowering The Cab p. 118](#) for proper cab tilting steps.

Be sure to use power steering fluid specified for this vehicle. See, [Fluids, Capacities And Lubricants p. 159](#) for more information.

NOTE:

For power steering service, maintenance, or inquiries, refer to the [Customer Assistance p. 162](#) chapter for contact information.

VEHICLE WHEELS AND TIRES



Front Tires



Dual Rear Tires

⚠ CAUTION!

- Caution must be taken for the initial 300 miles for new tires.
- When driving, be cautious to not hit any curbs. This can damage the tires.

1
2
3
4
5
6
7
8
9
10
11

MAINTENANCE AND SERVICE

CAUTION! (Continued)

- Frequently check whether the vehicle tires are damaged (puncture, cracks, or pits). Remove any foreign materials in/on the tread.
- Keep tires away from oil, grease, and fuel.
- If the dust cap on the valve stem is missing, replace it with a new one as soon as possible.
- Store the removed tire on a cool and dry place protected from sunlight.
- Avoid taking a turn at high speeds or suddenly accelerating into a turn.
- Frequently check whether the tire has abnormal abrasion. If tire has abnormal abrasion, please have the wheel alignment checked at an authorized Mullen service center.

Refer to the [Customer Assistance p. 162](#) chapter for service contact information on your tires.

New tires

For a new tire, its best adhesion force is still formed after breaking the tire in. Therefore, break in tires at a moderate speed and corresponding driving method in the initial 300 miles for "break-in". It can improve the life of the tire.

NOTE:

Excessively high or low tire pressures can greatly reduce the tire life and cause an adverse impact on the driving characteristics of the vehicle. The required air pressure of the front wheels and the rear wheels is found on the Tire and Loading Information label.

NOTE: (Continued)

See "[Tire Inflation Pressure p. 135](#)". The tires should be monitored regularly for proper inflation and rotated regularly according to the maintenance schedule.

WARNING!

- Operating the vehicle for long durations, at a high rate of speed with low tire pressure will cause deformation of the tire. The tire temperature will rise drastically which can lead to tread damage or tire blow out which could cause an accident or death.
- Check the wheel lug nuts for proper torque regularly to ensure proper adjustment and safety. Replace lug nuts if any damage is found. Use only authorized Mullen recommended lug nuts/wheel studs and clean or remove any dirt or oil before tightening.

Front wheel alignment

- Incorrect alignment of the front wheels can cause shaking/shimmying of the steering wheel, automatic steering "deflection", abnormal tire wear, and negatively effect the stability of the vehicle. In addition, it may also cause improper braking.
- Misaligned tires can cause the vehicle to stray left or right on the road surface. This may not be noticeable at first, but can worsen over time.

NOTE:

Have all wheel alignment work done at a Mullen authorized service center. See [Customer Assistance p. 162](#) chapter for service contact information.

Tire Safety Information

Tire safety information will cover aspects of the following information: Tire Markings, Tire Identification Numbers, Tire Terminology and Definitions, Tire Pressures and Tire Loading.

Tire Markings

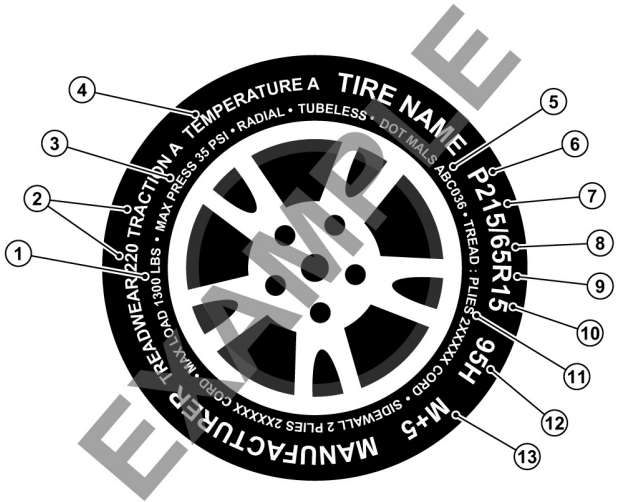

0101203160

Example of Tire Markings

On the side of your tire will be the following information:

- | | | |
|---|---|---|
| 1. Maximum Load Rating | 5. US DOT Tire ID Number | 9. Radial |
| 2. Traction & Treadwear Grade | 6. P (Passenger car) or LT (Light Truck) Size Designation | 10. Rim Diameter Code |
| 3. Maximum Permissible Inflation Pressure | 7. Nominal Width of Vehicle Tire in Diameters | 11. Tire Ply Composition & Materials Used |
| 4. Temperature Grade | 8. Aspect Ratio | 12. Load Index/Speed Symbol |
| | | 13. Severe Snow Conditions |

NOTE:

- P (Passenger) — Metric tire sizing is based on U.S. design standards. P-Metric tires have the letter “P” molded into the sidewall preceding the size designation. Example: P215/65R15 95H.
- European — Metric tire sizing is based on European design standards. Tires designed to this standard have the tire size molded into the sidewall beginning with the section width. The letter “P” is absent from this tire size designation. Example: 215/65R15 96H.

1
2
3
4
5
6
7
8
9
10
11

NOTE: (Continued)

- LT (Light Truck) — Metric tire sizing is based on U.S. design standards. The size designation for LT-Metric tires is the same as for P-Metric tires except for the letters “LT” that are molded into the sidewall preceding the size designation. Example: LT235/85R16.

Tires — General Information

Tire Pressure

Proper tire inflation pressure is essential to the safe and satisfactory operation of your vehicle. Four primary areas are affected by improper tire pressure:

- Safety and Vehicle Stability
- Energy Consumption
- Tread Wear
- Ride Comfort

WARNING!

- Improperly inflated tires are dangerous and can cause collisions.
- Under-inflation increases tire flexing and can result in overheating and tire failure.
- Over-inflation reduces a tire’s ability to cushion shock. Objects on the road and chuckholes can cause damage that result in tire failure.

WARNING! (Continued)

- Over-inflated or under-inflated tires can affect vehicle handling and can fail suddenly, resulting in loss of vehicle control.
- Unequal tire pressures can cause steering problems. You could lose control of your vehicle.
- Unequal tire pressures from one side of the vehicle to the other can cause the vehicle to drift to the right or left.
- Always drive with each tire inflated to the recommended cold tire inflation pressure.

Both under-inflation and over-inflation affect the stability of the vehicle and can produce a feeling of sluggish response or over responsiveness in the steering.

Battery Consumption

Under-inflated tires will increase tire rolling resistance resulting in reduced range.

Tread Wear

Improper cold tire inflation pressures can cause abnormal wear patterns and reduced tread life, resulting in the need for earlier tire replacement.

Ride Comfort And Vehicle Stability

Proper tire inflation contributes to a comfortable ride. Over-inflation produces a jarring and uncomfortable ride.

Tire Inflation Pressures

The proper cold tire inflation pressure is listed on the driver's side B-Pillar or rear edge of the driver's side door.

**INCOMPLETE VEHICLE MFD. BY
MULLEN AUTOMOTIVE, INC.**



DATE: _____ **GVWR:** xxxx LB / xxxx KG

GAWR F: xxxx LB / xxxx KG
with 7.00R16LT 8PR TIRES
16X5.50 RIMS at 66 PSI (460kPa) COLD

GAWR R: xxxx LB / xxxx KG
with 7.00R16LT 8PR TIRES
16X5.50 RIMS at 66 PSI (460kPa) COLD DUAL

VIN: _____

401000152

At least once a month:

- Check and adjust tire pressure with a good quality pocket-type pressure gauge. Do not make a visual judgement when determining proper inflation. Tires may look properly inflated even when they are under-inflated.
- Inspect tires for signs of tire wear or visible damage.

CAUTION!

After inspecting or adjusting the tire pressure, always reinstall the valve stem cap. This will prevent moisture and dirt from entering the valve stem, which could damage the valve stem.

- Inflation pressures specified on the placard are always “cold tire inflation pressure”. Cold tire inflation pressure is defined as the tire pressure after the vehicle has not been driven for at least three hours, or driven less than 1 mile (1.6 km) after sitting for a minimum of three hours. The cold tire inflation pressure must not exceed the maximum inflation pressure molded into the tire sidewall.
- Check tire pressures more often if subject to a wide range of outdoor temperatures, as tire pressures vary with temperature changes.
- Tire pressures change by approximately 1 psi (7 kPa) per 12°F (7°C) of air temperature change. Keep this in mind when checking tire pressure inside a garage, especially in the winter.
- Example: If garage temperature = 68°F (20°C) and the outside temperature = 32°F (0°C) then the cold tire inflation pressure should be increased by 3 psi (21 kPa), which equals 1 psi (7 kPa) for every 12°F (7°C) for this outside temperature condition.
- Tire pressure may increase from 2 to 6 psi (13 to 40 kPa) during operation. DO NOT reduce this normal pressure build up or your tire pressure will be too low.

1

2

3

4

5

6

7

8

9

10

11

MAINTENANCE AND SERVICE

Tire Inflation Check

Use an air pressure gauge to check for proper tire inflation when the tires are cold. If the inflation pressure is incorrect, adjust it to the indicated proper pressure.

CAUTION!

- Your vehicle's tires will heat up during use, causing an increase in air pressure. This is normal; do not release air from the tires when they are hot. Always check the tire pressures before driving, when the tires are cold.
- Pay close attention to the air pressure in new tires. New tires tend to stretch slightly as they settle, which can cause a decrease in air pressure.
- Never fail to install tire valve stem caps after checking or adjusting the air pressure. Unless the valve stem caps are reinstalled, foreign matter may contaminate the valve stem.

WARNING!

- Excessively high or low tire pressures not only give a poor ride, but also could cause any cargo to be damaged. Under-inflated or over-inflated tires are also very dangerous and can be easily damaged. Moreover, if the pressure is too low, tires could overheat and burst.
- Both the inner and outer tires on dual wheels should be inflated to the same pressure.
- Tires should be handled with care due to their high internal air pressure.

Tire Pressures For High Speed Operation

The manufacturer advocates driving at safe speeds and within posted speed limits. Where speed limits or conditions are such that the vehicle can be driven at high speeds, maintaining correct tire inflation pressure is very important. Increased tire pressure and reduced vehicle loading may be required for high-speed vehicle operation. Refer to an authorized tire dealer or original equipment vehicle dealer for recommended safe operating speeds, loading and cold tire inflation pressures.

Radial Ply Tires

WARNING!

Combining radial ply tires with other types of tires on your vehicle will cause your vehicle to handle poorly. The instability could cause a collision. Always use radial ply tires in sets of six. Never combine them with other types of tires.

Tire Repair

If your tire becomes damaged, it may be repaired if it meets the following criteria:

- The tire has not been driven on when flat.
- The damage is only on the tread section of your tire (sidewall damage is not repairable).
- The puncture is no greater than a $\frac{1}{4}$ of an inch (6 mm).

NOTE:

If tire repair, replacement, or service is needed, refer to the [Customer Assistance p. 162](#) chapter for contact information.

Damaged Run Flat tires, or Run Flat tires that have experienced a loss of pressure should be replaced immediately with another Run Flat tire of identical size and service description (Load Index and Speed Symbol).

Tire Spinning

When stuck in mud, sand, snow, or ice conditions, do not spin your vehicle's wheels above 30 mph (48 km/h) or for longer than 30 seconds continuously without stopping.

WARNING!

Fast spinning tires can be dangerous. Forces generated by excessive wheel speeds may cause tire damage or failure. A tire could explode and injure someone. Do not spin your vehicle's wheels faster than 30 mph (48 km/h) for more than 30 seconds continuously when you are stuck, and do not let anyone near a spinning wheel, no matter what the speed.

Life Of Tire

The service life of a tire is dependent upon varying factors including, but not limited to:

- Driving style.
- Tire pressure - Improper cold tire inflation pressures can cause uneven wear patterns to develop across the tire tread. These abnormal wear patterns will reduce tread life, resulting in the need for earlier tire replacement.
- Distance driven.

WARNING!

The tires should be replaced after six years, regardless of the remaining tread. Failure to follow this warning can result in sudden tire failure. You could lose control and have a collision resulting in serious injury or death.

Keep dismantled tires in a cool, dry place with as little exposure to light as possible. Protect tires from contact with oil, grease, and fuel.

NOTE:

For tire service, maintenance, or inquiries, refer to the [Customer Assistance p. 162](#) chapter for contact information.

Tire Tread Check

Inspect the entire circumference of each tire to make sure the remaining tread depth is sufficient for proper road surface contact.

NOTE:

Hydroplaning can occur when driving on wet roads at high speeds. When a vehicle hydroplanes, tires ride on top of a film of water, causing the driver to lose control of both steering and braking.

WARNING!

If the remaining tread is too shallow, the tires tend to skid and chances of "hydroplaning" during high speed driving increase. Worn tires should be replaced as soon as possible.

1

2

3

4

5

6

7

8

9

10

11

MAINTENANCE AND SERVICE

Replacement Tires

It is recommended to replace the two front tires or all rear tires. Replacing just one tire can seriously affect your vehicle's handling. If you ever replace a wheel, make sure that the wheel's specifications match those of the original wheels.

It is recommended you contact the Mullen service center with any questions you may have on tire specifications or capability. Failure to use equivalent replacement tires may adversely affect the safety, handling, and ride of your vehicle.

NOTE:

For service, maintenance, or inquiries, refer to the [Customer Assistance p. 162](#) chapter for contact information.

WARNING!

- Do not use a tire, wheel size, load rating, or speed rating other than that specified for your vehicle. Some combinations of unapproved tires and wheels may change suspension dimensions and performance characteristics, resulting in changes to steering, handling, and braking of your vehicle. This can cause unpredictable handling and stress to steering and suspension components. You could lose control and have a collision resulting in serious injury or death. Use only the tire and wheel sizes with load ratings approved for your vehicle.
- Never use a tire with a smaller load index or capacity, other than what was originally equipped on your vehicle. Using a tire with a smaller load index could result in tire overloading and failure. You could lose control and have a collision.

WARNING! (Continued)

- Failure to equip your vehicle with tires having adequate speed capability can result in sudden tire failure and loss of vehicle control.

WARNING!

Replacing original tires with tires of a different size may result in false speedometer and odometer readings.

Tire Types

All Season Tires

All Season tires provide traction for all seasons (Spring, Summer, Fall, and Winter). Traction levels may vary between different all season tires. All season tires can be identified by the M+S, M&S, M/S or MS designation on the tire sidewall. Use all season tires only in sets of six; failure to do so may adversely affect the safety and handling of your vehicle.

Summer or Three-Season Tires

Summer tires provide traction in both wet and dry conditions, and are not intended to be driven in snow or on ice. If your vehicle is equipped with Summer tires, be aware these tires are not designed for Winter or cold driving conditions. Install Winter tires on your vehicle when ambient temperatures are less than 40° F (5° C) or if roads are covered with ice or snow. For more information, contact an authorized dealer.

Summer tires do not contain the all season designation or mountain/snowflake symbol on the tire sidewall. Use Summer tires only in sets of four; failure to do so may adversely affect the safety and handling of your vehicle.

WARNING!

Do not use Summer tires in snow/ice conditions. You could lose vehicle control, resulting in severe injury or death. Driving too fast for conditions also creates the possibility of loss of vehicle control.

Snow Tires

Some areas of the country require the use of snow tires during the Winter. Snow tires can be identified by a “mountain/snowflake” symbol on the tire sidewall.

If you need snow tires, select tires equivalent in size and type to the original equipment tires. Use snow tires only in sets of six; failure to do so may adversely affect the safety and handling of your vehicle.

Snow tires generally have lower speed ratings than what was originally equipped with your vehicle and should not be operated at sustained high speeds.

While studded tires improve performance on ice, skid and traction capability on wet or dry surfaces may be poorer than that of non studded tires. Some states prohibit studded tires; therefore, local laws should be checked before using these tire types.

NOTE:

For service, maintenance, or inquiries, refer to the [Customer Assistance p. 162](#) chapter for contact information.

Wheel And Wheel Trim Care

All wheels and wheel trim, should be cleaned regularly using mild (neutral Ph) soap and water to maintain their luster and to prevent corrosion. Wash wheels with the same soap solution recommended for the body of the vehicle and remember to always wash when the surfaces are not hot to the touch.

Your wheels are susceptible to deterioration caused by salt, sodium chloride, magnesium chloride, calcium chloride, etc., and other road chemicals used to melt ice or control dust on dirt roads. Use a soft cloth or sponge and mild soap to wipe away promptly. Do not use harsh chemicals or a stiff brush. They can damage the wheel’s protective coating that helps keep them from corroding and tarnishing.

WARNING!

Avoid products or automatic car washes that use acidic solutions or strong alkaline additives or harsh brushes. Many aftermarket wheel cleaners and automatic car washes may damage the wheel’s protective finish

When cleaning extremely dirty wheels including excessive brake dust, care must be taken in the selection of tire and wheel cleaning chemicals and equipment to prevent damage to the wheels.

WARNING!

Do not use scouring pads, steel wool, a bristle brush, metal polishes or oven cleaner. These products may damage the wheel’s protective finish.

1

2

3

4

5

6

7

8

9

10

11

NOTE:

If you intend parking or storing your vehicle for an extended period after cleaning the wheels with wheel cleaner, drive your vehicle and apply the brakes to remove the water droplets from the brake components. This activity will remove the red rust on the brake rotors and prevent vehicle vibration when braking.

Tire Chains / Traction Devices

Use of traction devices require sufficient tire-to-body clearance. Follow these recommendations to guard against damage:

- Traction devices must be of proper size for the tire, for use of tire chains, or traction device service, or inquiries, refer to the [Customer Assistance p. 162](#) chapter for contact information..
- Install on Rear Tires.

WARNING!

Using tires of different size and type (M+S, Snow) between front and rear axles can cause unpredictable handling. You could lose control and have a collision.

CAUTION!

To avoid damage to your vehicle or tires, observe the following precautions:

- Because of restricted traction device clearance between tires and other suspension components, it is important that only traction devices in good condition are used. Broken devices can cause

CAUTION! (Continued)

serious damage. Stop the vehicle immediately if noise occurs that could indicate device breakage. Remove the damaged parts of the device before further use.

- Install device as tightly as possible and then retighten after driving about ½ mile (0.8 km).
- Do not exceed 30 mph (48 km/h).
- Drive cautiously and avoid severe turns and large bumps, especially with a loaded vehicle.
- Do not drive for a prolonged period on dry pavement.
- Observe the traction device manufacturer's instructions on the method of installation, operating speed, and conditions for use. Always use the suggested operating speed of the device manufacturer's if it is less than 30 mph (48 km/h).

Tire Rotation Recommendations

The tires on the front and rear of your vehicle operate at different loads and perform different steering, driving, and braking functions. For these reasons, they wear at unequal rates.

These effects can be reduced by timely rotation of tires. The benefits of rotation are especially worthwhile with aggressive tread designs such as those on all season type tires. Rotation will increase tread life, help to maintain mud, snow and wet traction levels, and contribute to a smooth, quiet ride.

NOTE:

For tire rotation service, maintenance, or inquiries, refer to the [Customer Assistance p. 162](#) chapter for contact information.

WARNING!

- Frequently check tire wear and remove any debris stuck in wheel tread.
- If the tire has any bumps, abnormal and serious wear or is becoming worn down to wear marks, check and replace the tire.
- Do not allow tires to come in contact with lubricating oil or fuel oil.
- Avoid long-term exposure to the sun when possible.
- If the valve stem cap is lost, have it replaced as soon as possible.
- Tires removed from the vehicle should be stored in a cool, dry place and keep out of the sun. Unused tires should be stored vertically.

Tire Rotation Diagram

The amount of wear on a tire depends on the load and its position on the vehicle. In order to maintain an equal amount of tread wear and increase service life, it is suggested to rotate the position of front and rear wheels in the sequence as shown in the following diagram every 5,000 miles (8,046 km) or every 6 months, whichever comes first. Depending on the road and driving conditions, it may be necessary for the tire rotation intervals to be shortened.

If different type tires are mounted on an axle, the vehicle could tend to pull to one side during braking, and could cause you to lose directional control of the vehicle.

When rotating the tires, check for proper lug nut torque, see [“Wheel And Tire Torque Specifications p. 155”](#). Follow the diagram indicating the correct tire locations for rotating the tires.

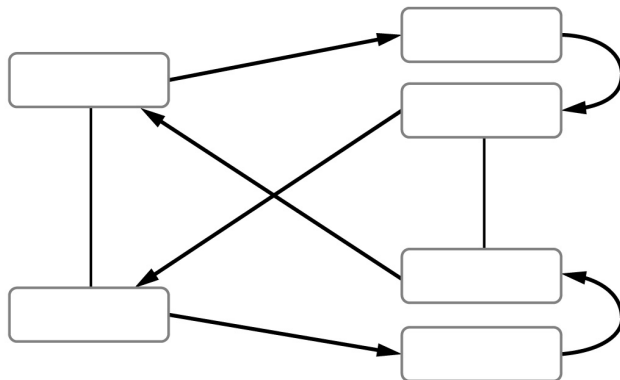

0101201487

NOTE:

The spare tire can be included in the rotation to maintain proper inflation, wear and use of the spare tire.

1

2

3

4

5

6

7

8

9

10

11

MAINTENANCE AND SERVICE

DEPARTMENT OF TRANSPORTATION UNIFORM TIRE QUALITY GRADES

The following tire grading categories were established by the National Highway Traffic Safety Administration. The specific grade rating assigned by the tire's manufacturer in each category is shown on the sidewall of the tires on your vehicle.

All passenger vehicle tires must conform to Federal safety requirements in addition to these grades.

Temperature Grades

The Temperature grades are A (the highest), B, and C, representing the tire's resistance to the generation of heat and its ability to dissipate heat, when tested under controlled conditions on a specified indoor laboratory test wheel.

Sustained high temperature can cause the material of the tire to degenerate and reduce tire life, and excessive temperature can lead to sudden tire failure. The grade C corresponds to a level of performance, which all passenger vehicle tires must meet under the Federal Motor Vehicle Safety Standard No. 109. Grades B and A represent higher levels of performance on the laboratory test wheel, than the minimum required by law.

WARNING!

The temperature grade for this tire is established for a tire that is properly inflated and not overloaded. Excessive speed, under-inflation, or excessive loading, either separately or in combination, can cause heat buildup and possible tire failure.

Traction Grades

The Traction grades, from highest to lowest, are AA, A, B, and C. These grades represent the tire's ability to stop on wet pavement, as measured under controlled conditions on specified government test surfaces of asphalt and concrete. A tire marked C may have poor traction performance.

WARNING!

The traction grade assigned to this tire is based on straight-ahead braking traction tests and does not include acceleration, cornering, hydroplaning or peak traction characteristics.

FUSE AND RELAY MAINTENANCE

WARNING!

Turn off the power to the vehicle to prevent power loss of the battery when the vehicle is in storage:

Prohibited actions include:

- The use of non-original fuses.
- Rinsing electrical cabin and electrical equipment with water.
- Unauthorized changes to the electrical system.
- Plugging in electrical components that are overheating.

Inspect the fuse box if you suspect a fuse is blown. Please inspect in accordance with the following procedures:

- Shut down and turn off all electrical switches.
- Set parking brake.
- Open the fuse box, and inspect each fuse. Pull outward to observe whether the fuse has been blown.
- If the fuse is burnt out, locate the interior and exterior fuse panel labels for the appropriate type and size of replacement fuse.

WARNING!

- Do not use damaged fuses as it may result in fires leading to vehicle damage and death.
- Only use replacement fuses with the same rated current, color, and dimension.
- If you have any questions, reach out to a Mullen authorized service provider.

Regularly check that the fuses and relays are plugged in securely. If you suspect that there is damage to the relay, follow these procedures:

- Find the fuse box with the appropriate function according to the indication label.
- Pull outward.
- Install a new relay.
- If the fault still can't be eliminated after replacement, please contact a Mullen authorized service provider.

NOTE:

For service, maintenance, or inquiries, refer to the [Customer Assistance p. 162](#) chapter for contact information.

1

2

3

4

5

6

7

8

9

10

11

LOW VOLTAGE BATTERY MAINTENANCE AND STORAGE

If the vehicle is parked for an extended period, (for example: more than 20 days), the 12 volt battery may lose charge and fail to start the vehicle. To prevent the low voltage battery from becoming depleted, periodically start the vehicle to allow the 12 volt battery to charge.

1. Apply the parking brake.
2. Turn the ignition key switch to the START/ON position.
3. The READY light will illuminate on the instrument cluster display.
4. Let the vehicle sit in READY state for 2 hours.
5. Then, turn the ignition key switch to the OFF position, the 12 volt battery should be fully charged.

NOTE:

Consider using a trickle charger on the low voltage battery if the vehicle will not be driven for more than 20 days. Keep the doors fully closed and locked when parking the vehicle to prolong the battery life.

OPERATION AND MAINTENANCE OF THE HIGH VOLTAGE BATTERIES

WARNING!

The high voltage batteries have no parts that a non-Mullen authorized service provider can service.

- Under no circumstances should anyone open or tamper with the batteries.
- Always contact a Mullen authorized service provider to arrange for battery servicing.
- Do not attempt to open the battery boxes.

NOTE:

For service, maintenance, or inquiries, refer to the [Customer Assistance p. 162](#) chapter for contact information.



0101203567

The high voltage batteries are located behind the cab on each side of the vehicle frame.

1

2

3

4

5

6

7

8

9

10

11

MAINTENANCE AND SERVICE

Requirements before performing battery maintenance

- Maintenance of the high voltage batteries and the vehicle's high voltage electrical system must be conducted by a qualified Mullen technician.
- The vehicle's high voltage electrical system must be powered OFF before performing any maintenance of the high voltage battery system. The master switch for the high voltage electrical system is located on the driver's side of the vehicle, behind the cab. The master switch must be turned to the horizontal "OFF" position, and the ignition key must be removed from the ignition.

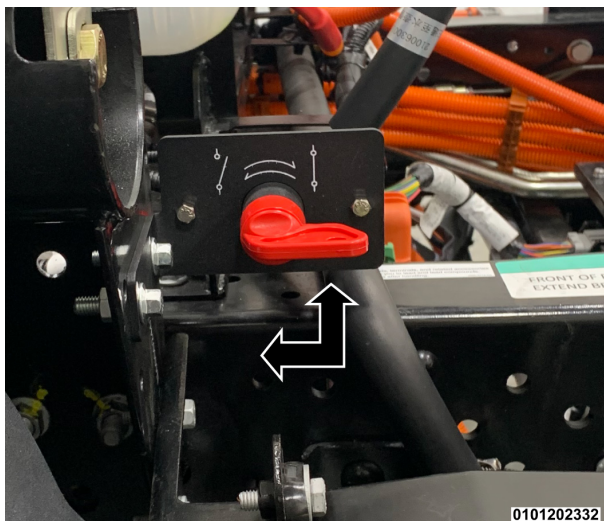

Master Switch (shown in the OFF position)

Visual inspection - Preparation before beginning

Inspect the high voltage battery boxes for damage, check for cracks, liquid leakage, etc. If any damage is found, refer to the [Customer Assistance p. 162](#) chapter for service contact information.

Maintenance details and proper use

- The high voltage battery system of the vehicle is equipped with a charging mode. In the charging mode, it is necessary to promptly charge the vehicle in accordance with the charging procedure if the State Of Charge (SOC) of high voltage battery system is lower than 20%.
- If the battery information is not displayed on the instrument cluster, refer to the [Customer Assistance p. 162](#) chapter for service contact information.
- Make sure that the high voltage battery's capacity (State Of Charge) displayed on the instrument cluster is between 30%~50% if the vehicle is not moving.
- Inspect the high voltage cables that connect the battery boxes for any damage, leaking, or exposed metal, check these every 1 to 2 months. If issues are found, refer to the [Customer Assistance p. 162](#) chapter for contact information for the closest Mullen authorized service provider.
- Inspect the batteries and the battery box mounting bolts to insure they are tight.

⚠ NOTE:

For service, maintenance, or inquiries, refer to the [Customer Assistance p. 162](#) chapter for contact information.

COOLING SYSTEM MAINTENANCE

High Voltage Battery Coolant System

The high voltage battery coolant reservoir is located to the right of the low voltage battery, on the driver side of the vehicle. Check the level on the side of the coolant reservoir. If the level is too low, add more coolant as soon as possible.



High Voltage Battery Coolant Reservoir

Adding coolant to the high voltage battery cooling system

Perform the following procedure, and carefully handle the battery coolant when filling the coolant reservoir. See, [Fluids, Capacities And Lubricants p. 159](#) for additional information.

- Turn the ignition OFF.
- Allow the high voltage batteries sufficient time to cool completely.
- Carefully remove the coolant reservoir cap and fill to the full line.
- Replace the coolant reservoir cap and tighten.

NOTE:

- When the temperature is lower than 32°F, the coolant level should be checked more frequently. Use a high quality coolant recommended by a Mullen authorized service provider. Do not use water as coolant, or mix different brands of coolants together. If the coolant needs to be fully drained, do not reuse the drained coolant.
- For service, maintenance, or inquiries, refer to the [Customer Assistance p. 162](#) chapter for contact information.

1

2

3

4

5

6

7

8

9

10

11

Drive Motor Coolant System

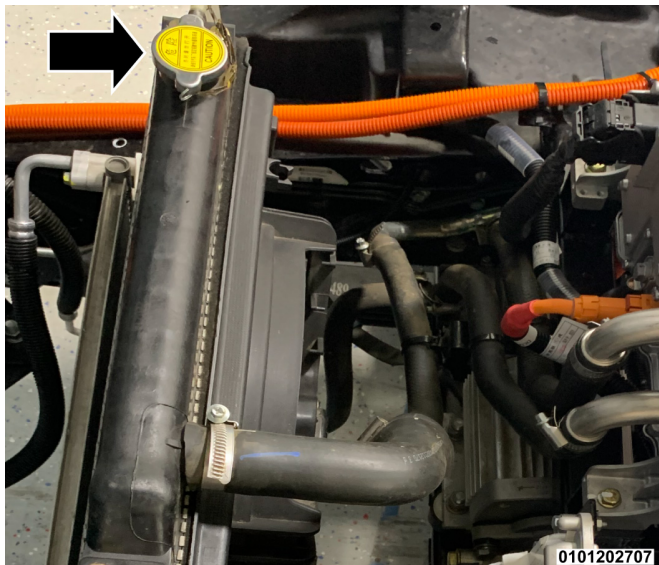

Drive Motor Cooling System Radiator

Adding coolant to the drive motor cooling system

Perform the following procedure, and carefully handle the drive motor coolant when filling the radiator. See, [Fluids, Capacities And Lubricants p. 159](#) for additional information.

- Turn the ignition OFF.
- Allow the drive motor sufficient time to cool completely.
- Carefully remove the radiator cap and fill until full.
- Replace the radiator cap and tighten.

⚠ NOTE:

- If the coolant needs to be refilled often, refer to [Customer Assistance p. 162](#) chapter for contact information for service. The drained coolant should be collected with a container and then disposed in line with the appropriate environmental protection regulations.

⚠ WARNING!

- Heat causes pressure to build up in the cooling system. Never open a hot cooling system, or attempt to loosen or remove the pressure cap when the coolant system is hot. To prevent scalding or injury, do not remove the pressure cap while the system is hot or under pressure. Otherwise, you may be burned.
- The cooling system coolant is poisonous. Avoid getting coolant on your skin, or near your mouth. To prevent ingestion by animals or children, do not store coolant in open containers or allow it to remain in puddles on the ground. Clean up any ground spills immediately. If the coolant is swallowed, seek medical help immediately.

INTERIOR AND EXTERIOR CLEANING

Exterior Cleaning

Appearance and Care

Make sure to properly maintain the exterior of your vehicle. Improper care and maintenance can void the warranty on exterior parts.

WARNING!

- Check with a Mullen authorized service provider about cleaning products that are approved for use with your vehicle. Some cleaning products can damage your vehicle and this may void the warranty on certain items.
- When washing the vehicle in winter, moisture or ice in the braking system will reduce the braking effects and can be dangerous. It is important to avoid water getting into the brake system during the winter.
- Only wash the vehicle when the ignition switch and master power switch are turned OFF. Personal injury or vehicle damage can occur if the vehicle is not turned off.
- Make sure doors and windows are securely closed when washing the vehicle to avoid water entry.

NOTE:

For service, maintenance, or inquiries, refer to the [Customer Assistance p. 162](#) chapter for contact information.

Exterior Care

Regularly washing your vehicle is the best way to protect the exterior. This can protect against:

- Body corrosion
- Paint dulling
- Seasonal road salt corrosion

Vehicle washing procedure

1. Only use mild car wash detergent.
2. Loosen dirt by first rinsing with water.
3. Evenly wash with soapy water using a vehicle sponge or clean cloth from top to bottom.
4. Quickly rinse the soap off the vehicle body with water. Do not let soap dry on paint.
5. Dry the vehicle body with a clean cloth.

Corrosive elements and debris can collect in crevices of the vehicle. Make sure that the drain holes on the vehicle door are clear of debris.

NOTE:

When washing in winter, make sure to avoid getting water on the locks and door jambs. Doing so can cause the doors and locks to freeze shut. Do not wipe the body surface with rough cloths or abrasive sponges to avoid scratching the paint.

1

2

3

4

5

6

7

8

9

10

11

WARNING!

- Do not use strong or abrasive chemical cleaning products.
- Make sure cleaning products are out of the reach of children.
- Make sure to pay attention when cleaning hard to reach areas of the vehicle so that you do not get injured or damage the paint while cleaning.

Waxing

Waxing the vehicle periodically will protect the paint surface and restore the look of a new vehicle.

Cleaning the underside of the vehicle

Make sure to clean the underside of the vehicle periodically, especially when driving on dirt or mud, or on salted road surfaces in winter. Large mounts of salt will result in corrosion of vehicle underside and suspension system.

WARNING!

Do not add any protective coating to any part of the vehicle that can become hot. Otherwise, the materials of the protective layer can be ignited during driving, resulting in a fire risk.

Paint damage

If the paint is damaged, chipped or scratched, it should be repaired immediately to avoid rust. If rust starts to build up, remove all the rust build up and apply a rust-proof paint. Make sure to also apply the top coat of paint.

Windows

Make sure your vehicles windows are clean and clear for the best possible driving condition.

1. Remove ice and snow on the windows and exterior mirrors with a plastic scraper. Do not use hot water to clear icy or frozen glass.
2. Clean the inside of the windows periodically with a glass cleaner and soft cloth to remove any film that has developed.
3. Do not use excessive force when scraping the windows. Windows can become scratched.
4. Clean the exterior of the windows along with the body using mild soap.

Vehicle wheels

Clean the wheel hubs and hub caps at the same time the rest of the vehicle exterior is being cleaned.

Protecting Against Exterior Corrosion

Rust Protection

The longer corrosive deposits stay on the body paint, the more serious the damages can become. Furthermore, high temperatures and sunlight will worsen the corrosion.

Common environmental factors that may result in vehicle corrosion are humidity, temperature extremes, and air pollution.

In order to prevent your vehicle from corrosion:

- Frequently clean and wax your vehicle.
- Frequently inspect for damage to paint on surface coat and have it repaired as soon as possible.
- It is important that the drain holes in the lower edges of the doors be kept clear and open. Spray water from vehicle bottom to the vehicle body and wheel casing to clean dust and salt.

- Check for and clean any accumulation of sand, dust or salt on the bottom of vehicle.
- Do not use a pressure washer on the cab to clean dust or other dirt.

Whenever possible, try to store or park your vehicle in a garage or indoor storage. If you can only park your vehicle outdoors, park in shady and cool locations or use a vehicle cover.

WARNING!

Do not expose any vehicle electrical components to water or other fluids.

Interior Cleaning

Seat Belts

Only properly functioning seat belts can ensure the driver and passengers safety.

Maintenance and cleaning for seat belts:

1. Use a mild detergent and soft sponge to clean stains.
2. Check the conditions of the seat belts regularly.

Upholstery

Reasonable maintenance and cleaning should be conducted to extend the life of the interior surfaces.

- Use a mild detergent and soft sponge to clean stains.
- Use a piece of cloth with good absorbency to remove any stains on the seat.

NOTE:

Avoid scratching fabric with sharp objects.

WARNING!

Do not dismantle any of the seat belts for cleaning. When unbuckled and rolled up, the seat belt must be dry. Do not clean the seat belt with chemical agents, it will damage the belt fabric. Any contact with corrosive liquid is not allowed. If the seat belt fabric, connectors, buckle etc. are damaged, replace them immediately.

Cleaning Cabin Air Filter

The cabin air filter is made of nylon and can be easily cleaned. The cabin air filter screen is located in the upper glove compartment in the air intake.

Maintenance

- Open the air intake of the air conditioning system in the upper glove compartment.
- Grasp the pull tabs on both sides and pull to remove the filter.
- Place the black filter in warm water mixed with a mild detergent.
- Rinse it with water and dry it completely.
- Insert the clean filter screen into the air intake with the pull tabs and push back in place.

NOTE:

- The cabin air filter screen should be cleaned regularly to maintain proper air quality in the cab of the vehicle.
- Periodically check to make sure the defroster works correctly and check for any blockages in the vents for best air flow.

1

2

3

4

5

6

7

8

9

10

11

IDENTIFICATION DATA	154
Vehicle Identification Number (VIN)	154
RECOMMENDED TIRE INFLATION PRESSURE	155
WHEEL AND TIRE TORQUE SPECIFICATIONS	155
TECHNICAL SPECIFICATIONS	156
WEIGHTS AND LOADS	158
FLUID CAPACITIES AND LUBRICANTS	159

1
2
3
4
5
6
7
8
9
10
11

RECOMMENDED TIRE INFLATION PRESSURE

The proper cold tire inflation pressure is listed on the Tire And Loading Information label found on the driver's side B-Pillar or rear edge of the driver's side door. See [Tire Inflation Pressures p. 135](#) for label information.

At least once a month:

- Check and adjust tire pressure with a good quality pocket-type pressure gauge. Do not make a visual judgement when determining proper inflation. Tires may look properly inflated even when they are under-inflated.
- Inspect tires for signs of tire wear or visible damage.

CAUTION!

After inspecting or adjusting the tire pressure, always reinstall the valve stem cap. This will prevent moisture and dirt from entering the valve stem, which could damage the valve stem.

Inflation pressures specified on the placard are always "cold tire inflation pressure." Cold tire inflation pressure is defined as the tire pressure after the vehicle has not been driven for at least three hours, or driven less than 1 mile (1.6 km) after sitting for a minimum of three hours. The cold tire inflation pressure must not exceed the maximum inflation pressure molded into the tire sidewall.

Check tire pressures more often if subject to a wide range of outdoor temperatures as tire pressures vary with temperature changes.

Tire pressures change by approximately 1 psi (7 kPa) per 12° F (7° C) of air temperature change. Keep this in mind when checking tire pressure inside a garage, especially in the winter.

Tire pressure may increase from 2 to 6 psi (13 to 40 kPa) during operation. DO NOT reduce this normal pressure build up or your tire pressure will be too low.

WHEEL AND TIRE TORQUE SPECIFICATIONS

Proper lug nuts torque is very important to ensure that the wheel is properly mounted to the vehicle. Any time a wheel has been removed and reinstalled on the vehicle, the lug nuts/bolts should be torqued using a properly calibrated torque wrench using a high quality six sided (hex) deep wall socket.

Refer to the [Customer Assistance p. 162](#) chapter for contact information for a Mullen authorized service provider to check the torque of the lug nuts.

Torque Specifications

Lug Nut Torque	Lug Nut / Socket Size
273 - 332 Ft Lbs. (370~450 Nm)	M18* 1.5 (Hex. socket width 30 mm) 1 3/16 (30 mm)
*Only use lug nuts recommended by Mullen. Clean and remove any dirt or oil before tightening.	

Inspect the wheel mounting surface prior to mounting the tire and remove any corrosion or loose particles.

1

2

3

4

5

6

7

8

9

10

11

SPECIFICATIONS

Tighten the lug nuts in the following pattern until each nut has been tightened twice.

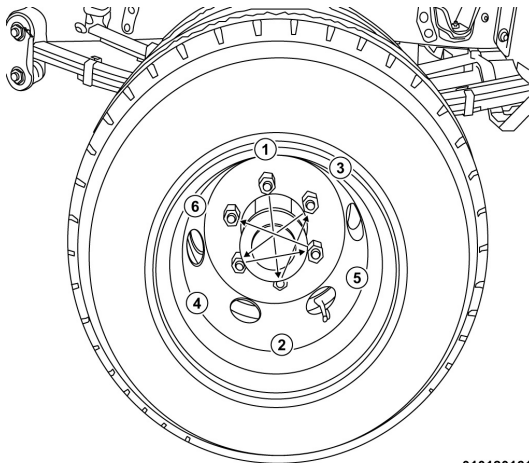

0101201611

After 25 miles (40 km), check the lug nut torque to be sure that all the lug nuts are properly seated against the wheel.

! WARNING!

To avoid the risk of the vehicle falling off the jack, do not tighten the lug nuts fully until the vehicle has been lowered. Failure to follow this warning may result in personal injury.

TECHNICAL SPECIFICATIONS

Technical Parameters of the Vehicle

Specification		Parameter
Total Weight (kg)		GVWR: 11,000 lb (4,990 kg)
Curb Weight (kg)		5,198 lbs (2,358 kg)
Wheelbase (mm)		130 inches (3,308 mm)
Front/Rear GAWR (Gross Axle Weight Rate) (kg)		Front GAWR: 4,300 lbs (1,950 kg) Rear GAWR: 6,725 lbs (3,050 kg)
Dimensions (mm)	Length	230 inches (5,853 mm)
	Width	103.7 inches (2,634 mm)
	Height	Without air deflector: 87 inches (2,209 mm) With air deflector: 116 inches (2,946 mm)
Tire Size		7.00R16LT
Number of Passengers in Cab		3
Maximum Speed (km/h)		65 mph (105 km/h)

NOTE:

- Curb weight excludes the mass of the optional components.
- Vehicle noises, braking and other vehicle performance characteristics comply with relevant stipulations 49 CFR Part 571; Subpart B Federal Motor Vehicle Safety Standards (FMVSS).
- The vehicle load carrying capacity is not increased by the number of leaf springs or cushion blocks used to adjust the vehicle angle for load leveling.

The following components of the vehicle are not within the vehicle length measurement range:

- Wipers and washers.
- Lighting and turn signal devices.
- Anti-collision bump stops and similar devices.
- External solar protection devices. For example, an external sun visor.
- Devices used to fasten mud flaps.
- Locking devices, hinges, handles, controllers and switches.
- Steps (or ladder stand) at exit and entrance.
- Rear identification plate including LOGO.
- Detachable hanging or dragging device for vehicles.
- Indirect view devices.
- Lift gate, tail boards, and other similar devices.

The following components at both sides of the vehicle are not within the vehicle width measurement range:

- Lighting and turn signal devices.
- Anti-collision bump stops and similar devices.
- Devices used to fasten mud flaps.
- Rain channel/gutter (used to guide rain flow away from top of the doors and both sides of the windshield).
- Locking devices, hinges, handles, controllers and switches.
- Deformed parts of the tire.
- Mirrors.

Following components on top of the vehicle are not within the vehicle height measurement range:

- Soft parts of the antenna.

1

2

3

4

5

6

7

8

9

10

11

SPECIFICATIONS

WEIGHTS AND LOADS

Gross Vehicle Weight Rating (GVWR)	11,000 lb (4,990 kg)
Front Gross Axle Weight Rating (GAWR)	4,300 lb (1,950 kg)
Rear Gross Axle Weight Rating (GAWR)	6,725 lb (3,050 kg)
Maximum Payload	5,316 lbs (2,422 kg)

FLUID CAPACITIES AND LUBRICANTS

Component	Item	Type	Capacity
Brake System	Brake Fluid	DOT 4	22.6 Ounce (670 ml)
Power Steering System	Hydraulic Transmission Fluid	ATF 330 (Alternative ATF if not available Mobil ATF 3309)	1.7 Quart (1.6 L)
Windshield Washer Fluid	—	Windshield Washer Solvent	2.7 Quart (2.6 L)
Air Conditioning System	Freon	R134A	0.88 Lbs (0.4 Kg)
Air Conditioning System Oil	POE Oil	POE 68	4.4 Ounce (130 ml)
Rear Axle Oil/Fluid Refill	Gear Oil	GL-5 85W-90 (Summer) GL-5 75W-90 (Winter)	2.7 Quart (2.6 L) The refill shall be filled until the fluid level is even with the observation port, and shall not overflow from the port.
Drive Motor/Transmission Oil/Fluid Refill			0.5/0.7 Quart (0.5/0.7 L) The refill shall be filled until the fluid level is even with the fill port without overflowing or shall follow the instructions specified on the transmission nameplate.

1

2

3

4

5

6

7

8

9

10

11

SPECIFICATIONS

Component	Item	Type	Capacity
Drive Motor Coolant (With reservoir at MAX level)	YA-992 Prestone Cor-Guard Antifreeze Coolant (Antifreeze Coolant must meet or exceed ASTM D3306 & D4985)	-13° F (-25° C) (Summer) -31° F (-35° C) (Winter)	1.8 Gallon (6.8 L)
Battery Thermal System Coolant (With reservoir at MAX level)			3.6 Gallon (13.6 L)
Chassis Grease	No.2 General-purpose, Lithium-based Grease	—	—

IF YOU NEED ASSISTANCE	162
Mullen Automotive Customer Solutions Support Team	162
Service Contract	162
WARRANTY INFORMATION	163
PARTS INFORMATION	163
REPORTING SAFETY DEFECTS	164
PUBLICATION ORDERING	164

1
2
3
4
5
6
7
8
9
10
11

CUSTOMER ASSISTANCE

IF YOU NEED ASSISTANCE

Please visit us at www.mullenusa.com or contact our Customer Solutions Support Team. For service inquiries, please email service@mullenusa.com. You can also refer to the Mullen Vehicle Center website for the most up to date information on your vehicle www.mullenusa.com/mullen-vehicle-center.

Mullen Automotive Customer Solutions Support Team
Mullen

5755 New King Dr. Troy, MI 48098
(248) 988-4498

Any communication to the manufacturer's customer center should include the following information:

- Owner's name and address
- Owner's telephone number
- Vehicle Identification Number (VIN)
- Vehicle delivery date and mileage

Mullen Automotive Customer Solutions Support Team

For Parts, Service and Warranty, please contact the Mullen Automotive Customer Solutions Support Team.

(248) 988-4498

Email:

Or visit: www.mullenusa.com

Address: Mullen

5755 New King Dr.

Troy, MI 48098

*****For emergencies, dial 911*****

Service Contract

We appreciate that you have made a major investment when you purchased the vehicle. A Mullen authorized service provider has also made a major investment in facilities, tools, and training to assure that you are happy with the ownership experience. You will be pleased with their sincere efforts to resolve any warranty issues or related concerns.

If you are interested in obtaining a service contract for your vehicle, please contact a Mullen authorized service provider for more information.

WARRANTY INFORMATION

See the Warranty information available online by scanning the QR code below for Mullen warranties applicable to this vehicle and market.

www.mullenusa.com/mullen-vehicle-center

If you have additional questions, reach out to your authorized Mullen Automotive Customer Solutions Support Team.

For service inquiries, email service@mullenusa.com or call.

Phone: (248) 988-4498



0101201447

PARTS INFORMATION

You can contact Mullen for fluids, lubricants, and parts for your vehicle through our Customer Solutions Support Team or email service@mullenusa.com for parts or service information.

Mullen Automotive Customer Solutions Support Team
Mullen

5755 New King Dr. Troy, MI 48098

(248) 988-4498

Additional information is also available on our website at www.mullenusa.com.

1

2

3

4

5

6

7

8

9

10

11

CUSTOMER ASSISTANCE

REPORTING SAFETY DEFECTS

If you believe that your vehicle has a defect which could cause a crash or could cause injury or death, you should immediately inform the National Highway Traffic Safety Administration (NHTSA) in addition to notifying Mullen.

If NHTSA receives similar complaints, it may open an investigation, and if it finds that a safety defect exists in a group of vehicles, it may order a recall and remedy campaign. However, NHTSA cannot become involved in individual problems between you, your dealer, or Mullen.

To contact NHTSA, you may call the Vehicle Safety Hotline toll-free at 1(888) 327-4236 (TTY: 1-800-424-9153); go to <http://www.safercar.gov>; or write to: Administrator, NHTSA, 400 Seventh Street, SW., Washington, DC 20590. You can also obtain other information about motor vehicle safety from <http://www.safercar.gov>.

PUBLICATION ORDERING

To find the most up to date information on your vehicle, visit the Mullen Vehicle Center website at: www.mullenusa.com/mullen-vehicle-center

Or to access the Owner's Manual digitality, scan the QR code below. If you have additional questions, reach out to your authorized Mullen Automotive Customer Solutions Support Team.

For service inquiries, email service@mullenusa.com or call.

Phone: (248) 988-4498



SCAN CODE
TO ACCESS
MANUALS
AND GUIDES

AGID-001X-AC

0101201447

ACCELERATOR AND BRAKE PEDALS		
Acceleration90	
Braking And Parking90	
ANTENNA		
Antenna40	
BACKUP CAMERA (IF EQUIPPED)		
Parking Sensor — If Equipped94	
BRAKE FLUID RESERVOIR129	
BULB REPLACEMENT104	
CLIMATE CONTROLS		
A/C (Air Conditioner) Button77	
Adjustable Vents75	
Climate Control Overview75	
Fan Speed Dial75	
Heat Button77	
Mode Control Dial76	
Recirculation Button77	
COOLING SYSTEM MAINTENANCE147	
DAILY MAINTENANCE123	
DECLARATION3	
DEPARTMENT OF TRANSPORTATION UNIFORM TIRE QUALITY GRADES		
Temperature Grades142	
Traction Grades142	
DOORS		
Vehicle Door Locks27	
DRIVING TIPS		
Attentive Driving98	
Driving Through Slippery Surfaces98	
Driving Through Water99	
On-Road Driving Tips98	
Proper Use Of Vehicle97	
EXTERIOR LIGHTS		
Front Exterior Lights35	
Multifunction Headlight Control Lever34	
FLUID CAPACITIES AND LUBRICANTS159	
FREEDING A STUCK VEHICLE114	
FRONT VIEW10	
FUSE AND RELAY MAINTENANCE143	
FUSE REPLACEMENT		
Exterior Power Distribution Fuses107	
Interior Power Distribution Fuses106	
GEAR SHIFT SELECTOR93	
GENERAL DISCLAIMER6	
HAZARD SWITCH102	
HIGH VOLTAGE BATTERY EMERGENCIES103	
HIGH VOLTAGE CHARGING OPERATION		
Battery Maintenance22	
Charging Port Door18	
E-Lock Actuator19	
Maximizing High Voltage Battery Life21	
Vehicle Charging19	
HIGH VOLTAGE SYSTEM COMPONENTS		
High Voltage Batteries16	
HOW TO USE THIS MANUAL		
Symbols4	
IDENTIFICATION DATA		
Vehicle Identification Number (VIN)154	
IF YOU NEED ASSISTANCE		
Mullen Automotive Customer Solutions Support Team162	
Service Contract162	
IGNITION SWITCH		
Ignition Switch Positions26	
IMPROVING VEHICLE DRIVING RANGE89	
INSTRUMENT CLUSTER DISPLAY		
Digital Cluster System Information48	
Instrument Cluster Features46	
INSTRUMENT PANEL12	

1
2
3
4
5
6
7
8
9
10
11

INDEX

INTERIOR AND EXTERIOR CLEANING	
Cleaning Cabin Air Filter	151
Exterior Cleaning	149
Interior Cleaning	151
Protecting Against Exterior Corrosion.	150
INTERIOR LIGHTS	
Dome Light	36
Interior Brightness Control	37
INTERNAL FEATURES	
Cigarette Lighter And Ashtray	43
Cup Holders	42
Interior Storage	41
Sun Visor	42
JACKING AND TIRE CHANGING	
Jacking Locations	111
Jacking Steps	112
Spare Tire And Winch	113
Wheel Installation	113
JUMP-STARTING (12-VOLT) BATTERY.	108
KEYS	
General Information	25
Key Fob Functions	24
Types of Keys	23
LOW VOLTAGE BATTERY MAINTENANCE AND STORAGE	144
MAINTENANCE INTERVALS	124
MIRRORS	
Exterior Side Mirrors	33
NEW VEHICLE BREAK-IN MAINTENANCE	86
OCCUPANT RESTRAINT SYSTEMS	
Disengaging The Seat Belt	82
Fastening The Seat Belt	82
Seat Belts	81
OPERATION AND MAINTENANCE OF THE HIGH VOLTAGE BATTERIES	144
OWNER'S MANUAL INTRODUCTION	
Additional Information.	2
PARKING BRAKE LEVER	91
PARTS INFORMATION	163
POWER STEERING FLUID RESERVOIR	130
PUBLICATION ORDERING	164
REAR VIEW	11
RECOMMENDED TIRE INFLATION PRESSURE	155
REGENERATIVE BRAKING SYSTEM.	91
REPORTING SAFETY DEFECTS	164
ROADSIDE PROCEDURES	104
ROLLOVER WARNING	5
SAFETY FEATURES	
Anti-Lock Brake System (ABS).	80
Anti-lock Brake System Precautions	80
SAFETY TIPS	
Periodic Safety Checks Outside The Vehicle	84
Safety Checks Inside The Vehicle	83
SEATS	
Driver Seat Adjustment	29
Fold Flat Passenger Seats	30
STARTING THE VEHICLE	
Shutting Down The Vehicle	88
Start Up Troubleshooting	87
STATEMENT	3
STEERING WHEEL	
Horn	33
Manual Tilt Steering Column Lever	31
Steering Wheel Radio Controls	32
TECHNICAL SPECIFICATIONS	156
TELEMATICS	
Telematics General Information.	74
Telematics Getting Started	74
TILTING AND LOWERING THE CAB	118

TOUCHSCREEN DISPLAY RADIO			
BluePhone Screen	.61	Replacement Tires	.138
Bluetooth®	.59	Snow Tires	.139
Bluetooth® Playlist Functions	.67	Summer or Three-Season Tires	.138
Cleaning your Radio Touchscreen	.58	Tire Chains / Traction Devices	.140
General Information	.58	Tire Inflation Check	.136
Media Mode	.64	Tire Inflation Pressures	.135
Music Operation	.64	Tire Markings	.133
Pairing a Phone/Bluetooth® Device	.59	Tire Pressure	.134
Phone Mode	.61	Tire Pressures For High Speed Operation	.136
Radio Home Screen	.58	Tire Repair	.136
Radio Introduction	.58	Tire Rotation Diagram	.141
Radio Mode	.63	Tire Rotation Recommendations	.140
Radio Operation	.63	Tire Safety Information	.133
Radio Settings	.68	Tires — General Information	.134
Unpairing A Phone	.60	Tire Spinning	.137
TOWING	.115	Tire Tread Check	.137
VEHICLE LOADING DESCRIPTIONS		Tire Types	.138
Certification Label	.96	Wheel And Wheel Trim Care	.139
Curb Weight	.96	WARNING LIGHTS AND MESSAGES	
Gross Axle Weight Rating (GAWR)	.96	Anti-Lock Brake (ABS) Warning Light	.53
Gross Vehicle Weight Rating (GVWR)	.96	Anti-Theft Light	.54
Inflation Pressure	.96	Brake System Indicator Light	.55
Loading	.96	Charging Plug Connection Light	.55
Payload	.96	Drive Motor Fault Light	.55
Rim Size	.96	Driving Power Limited Light	.53
Tire Size	.96	Electronic Brake Distribution (EBD) - Light	.56
VEHICLE MAINTENANCE	.122	Electronic Power Steering Light	.54
Installing of Radio Transmitting Equipment	.5	Front Fog Light	.57
VEHICLE WHEELS AND TIRES		Hazard Lights	.56
All Season Tires	.138	High Beams Indicator	.57
Life Of Tire	.137	High Voltage Battery Fault Light	.55
Radial Ply Tires	.136	Low Charging Status Light	.54
		Parking Brake Light	.56
		Parking/Headlights Indicator Light	.57

1
2
3
4
5
6
7
8
9
10
11

INDEX

READY Light57
Rear Fog Lights54
Seat Belt Reminder Light56
Turn Indicator Lights57
Vehicle Disable Indicator57
WARRANTY INFORMATION.163
WEIGHTS AND LOADS158
WHEEL AND TIRE TORQUE SPECIFICATIONS.155
WINDOWS	
Power Windows39
WINDSHIELD WASHER FLUID RESERVOIR	
Wiper Blade Removal128
WINDSHIELD WIPERS AND WASHERS	
Windshield Wiper And Washer Lever38

Strikingly Different™



mullenusa.com/mullen-vehicle-center



Part# AGIB-301X-AB